

# KENWOOD

AUDIO VIDEO SURROUND RECEIVER

## KRF-X9090D

### INSTRUCTION MANUAL

Kenwood Corporation

***About the supplied remote control***

Compared to standard remote controls, the remote control supplied with this model has several operation modes. These modes enable the remote control unit to control other audio/video components. In order to effectively use the remote control it is important to read the operating instructions and obtain a proper understanding of the remote control and how to switch its operation modes (etc.). Using the remote control without completely understanding its design and how to switch the operation modes may result in incorrect operations.



**6CH INPUT**



# Before applying the power

 **Caution : Read this page carefully to ensure safe operation.**

Units are designed for operation as follows.

U.S.A. and Canada ..... AC 120 V only  
Australia ..... AC 240 V only  
Europe ..... AC 230 V only  
Other countries ..... AC 110-120 / 220-240 V switchable

## Information on Disposal of Old Electrical and Electronic Equipment (applicable for EU countries that have adopted separate waste collection systems)



Products with the symbol (crossed-out wheeled bin) cannot be disposed as household waste. Old electrical and electronic equipment should be recycled at a facility capable of handling these items and their waste byproducts. Contact your local authority for details in locating a recycle facility nearest to you. Proper recycling and waste disposal will help conserve resources whilst preventing detrimental effects on our health and the environment.

## How to use this manual

This manual is divided into four sections, Preparations, Operations, Remote Control, and Additional Information.

### Preparations

Shows you how to connect your audio and video components to this model and prepare the surround processor. Since this model works with all your audio and video components, kindly follow the instructions in this manual for the correct connections.

### Operations

Shows you how to operate the various functions available on this model.

### Remote Control

Shows you how to operate other components using the remote control, as well as a detailed explanation of all remote control operations. Once you have registered your components with the proper setup codes, you'll be able to operate both this receiver and your other AV components (TV, VCR, DVD player, CD player, etc.) using the remote control supplied with this receiver.

### Additional Information

Shows you additional information such as "In case of difficulty" (troubleshooting) and "Specifications".

## Safety precautions

### WARNING :

TO PREVENT FIRE OR ELECTRIC SHOCK, DO NOT EXPOSE THIS APPLIANCE TO RAIN OR MOISTURE.

### Maintenance of the unit

When the front panel or case becomes dirty, wipe with a soft, dry cloth. Do not use thinner, benzine, alcohol, etc. for these agents may cause discoloration.

### In regard to contact cleaner

Do not use contact cleaners because it could cause a malfunction. Be specially careful not to use contact cleaners containing oil, for they may deform the plastic component.



**CAUTION**  
RISK OF ELECTRIC SHOCK  
DO NOT OPEN



CAUTION: TO REDUCE THE RISK OF ELECTRIC SHOCK, DO NOT REMOVE COVER (OR BACK). NO USER-SERVICEABLE PARTS INSIDE. REFER SERVICING TO QUALIFIED SERVICE PERSONNEL.





THE LIGHTNING FLASH WITH ARROWHEAD SYMBOL, WITHIN AN EQUILATERAL TRIANGLE, IS INTENDED TO ALERT THE USER TO THE PRESENCE OF UNINSULATED "DANGEROUS VOLTAGE" WITHIN THE PRODUCT'S ENCLOSURE THAT MAY BE OF SUFFICIENT MAGNITUDE TO CONSTITUTE A RISK OF ELECTRIC SHOCK TO PERSONS.



THE EXCLAMATION POINT WITHIN AN EQUILATERAL TRIANGLE IS INTENDED TO ALERT THE USER TO THE PRESENCE OF IMPORTANT OPERATING AND MAINTENANCE (SERVICING) INSTRUCTIONS IN THE LITERATURE ACCOMPANYING THE APPLIANCE.

## Contents

**Caution** : Read the pages marked  carefully to ensure safe operation.

	<b>Before applying the power</b> .....	<b>2</b>
	Safety precautions .....	2
	How to use this manual .....	2
	Unpacking .....	4
	Preparing the remote control .....	4
	Special features .....	5
	<b>Names and functions of parts</b> .....	<b>6</b>
	Main Unit .....	6
	Remote control unit .....	7

<b>Preparations</b>	<b>Setting up the system</b> .....	<b>8</b>
	Connecting the terminals .....	9
	Connecting a DVD player (6-channel input) .....	10
	Connecting audio components .....	11
	Connecting video components .....	12
	Digital connections .....	13
	Connecting video components (COMPONENT VIDEO) .....	14
	Connecting the speakers .....	15
	PRE OUT connections .....	16
	Connecting to another room (ROOM B) .....	17
	Connecting to the AV AUX jacks .....	18
	Connecting the antennas .....	18
	<b>Preparing for surround sound</b> .....	<b>19</b>
	Before setting up the speakers .....	19
	Setting up the speakers automatically (AUTO SETUP) "Kenwood Room Acoustic Calibration" .....	20
Setting up the speakers manually (MANUAL SETUP) .....	22	
Other settings .....	24	

<b>Operations</b>	<b>Normal playback</b> .....	<b>26</b>
	Preparing for playback .....	26
	Listening to a source component .....	26
	Input level adjustment (analog sources only) ..	27
	Adjusting the sound .....	27
	<b>Recording</b> .....	<b>29</b>
	Recording audio (analog sources) .....	29
	Recording audio (digital sources) .....	29
	Recording video .....	29
	<b>Listening to radio broadcasts</b> .....	<b>30</b>
	Tuning (non-RDS) radio stations .....	30
	Using RDS (Radio Data System) .....	30
	Presetting radio stations manually .....	31
	Receiving preset stations .....	31
	Receiving preset stations in order (P.CALL) ...	31
Using the RDS DISP (Display) key .....	32	
Presetting RDS stations (RDS AUTO MEMORY) .....	32	
Tuning by Program TYpe (PTY search) .....	33	
<b>Ambience effects</b> .....	<b>34</b>	
Surround modes .....	34	
Surround play .....	37	
Virtual modes .....	39	
DVD 6-channel playback .....	39	
Adjusting the sound .....	40	
<b>Convenient functions</b> .....	<b>42</b>	
Display dimmer adjustment .....	42	
Sleep timer .....	42	

### Remote Control

<b>Basic remote control operations for other components</b> .....	<b>43</b>
Registering setup codes for other components .....	43
Searching for your codes .....	43
Checking the codes .....	43
Re-assigning device keys .....	44
Operating other components .....	44
Storing the remote control code of the other components .....	45
Setup code chart .....	46
Other components' operations .....	58

### Additional Information

<b>In case of difficulty</b> .....	<b>62</b>
 <b>Specifications</b> .....	<b>64</b>

## Unpacking

Unpack the unit carefully and make sure that all accessories are present.

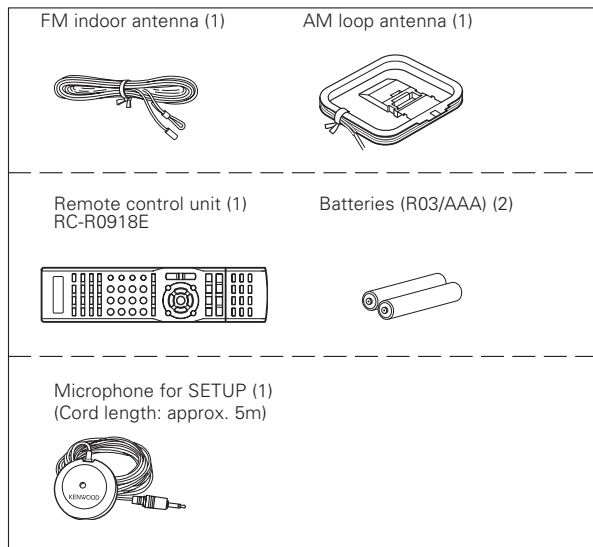

If any accessories are missing, or if the unit is damaged or fails to operate, notify your dealer immediately. If the unit was shipped to you directly, notify your shipper immediately. Kenwood recommends that you retain the original carton and packing materials in case you need to move or ship the unit in the future.

Keep this manual handy for future reference.

## Preparing the remote control

### Loading the batteries

① Remove the cover.

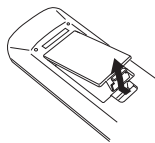

② Insert the batteries.

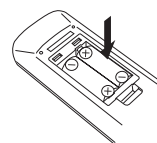

③ Close the cover.

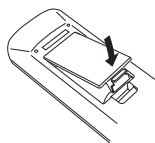

- Insert two AAA-size (R03) batteries as indicated by the polarity markings.

### Operation

When the standby indicator is lit, the power turns ON when you press the **RECEIVER ON** key on the remote control. When the power comes ON, press the key you want to operate.

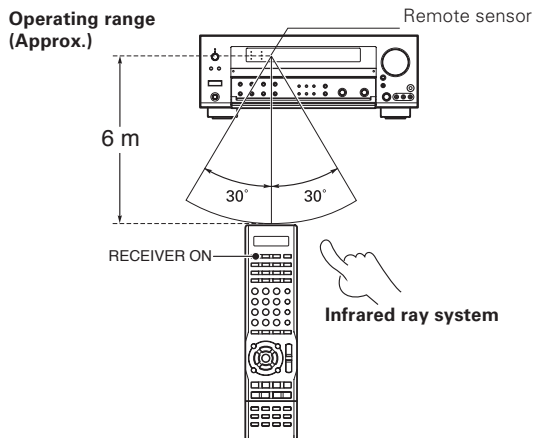

- When pressing more than one remote control key successively, press the keys securely by leaving an interval of 1 second or more between keys.

### Notes

1. The supplied batteries may have shorter lives than ordinary batteries due to use during operation checks.
2. When the remote-controllable distance gets shorter than before, replace both batteries with new ones.
3. Placing the remote sensor in direct sunlight, or in direct light from a high frequency fluorescent lamp may cause a malfunction. In such a case, change the location of the system installation to prevent malfunction.

## **Special features**

### **True home theater sound**

→ 34

This model incorporates a wide variety of surround modes to bring you maximum enjoyment from your video software. Select a surround mode according to your equipment or the software you are going to play and enjoy!

- THX Select2 Cinema
- THX MusicMode
- THX Games
- THX Surround EX
- Dolby Digital EX
- Dolby Pro Logic IIx
- Dolby Digital
- Dolby Virtual Speaker
- Dolby Headphone
- DTS-ES
- DTS Neo:6
- DTS 96/24
- DTS
- DSP Mode

### **Kenwood Room Acoustic Calibration**

→ 20

Without going through a complicated manual setup procedure, this function automatically measures the capacity of your speaker system, speaker layout and acoustic specifications of your listening room correctly with the provided microphone, and provides the best listening environment.

### **ACTIVE EQ**

→ 27

ACTIVE EQ mode will produce a more dynamic sound quality in any condition. You can enjoy a more impressive sound effect when ACTIVE EQ is turned on.

### **GAME mode function**

→ 26

When you connect a game machine to the **AV AUX** jacks on the front panel, the input selector of the receiver switches automatically to "GAME" and the optimum sound field for enjoying games is set.

This feature improves your convenience in playing video games.

### **Universal IR (InfraRed) remote control**

In addition to the basic receiver operations, the remote control unit supplied with this receiver can also operate almost all of your remote controllable audio and video components. Just follow the simple setup procedure to register the components you have connected.

### **Video up conversion**

This receiver can convert the incoming composite video signals to S-Video signal.

If your monitor TV has S-Video jacks, it is not necessary to do the composite video connections, just use an S-Video cord to connect the receiver and your monitor TV.

### **RDS (Radio Data System) tuner**

This model is equipped with an RDS tuner that provides several convenient tuning functions: RDS Auto Memory, to automatically preset up to 40 RDS stations broadcasting different programs; station name display, to show you the name of the current broadcast station; and PTY search to let you tune stations by program type.

### **PTY (Program TYPe) search**

Tune the stations by specifying the type of program you want to hear.

# Names and functions of parts

## Main unit

\* Input channel indicators

Input channel indicators light up according to the incoming audio signals. "S" indicator will light up when the surround component of the audio signals is only 1 channel.

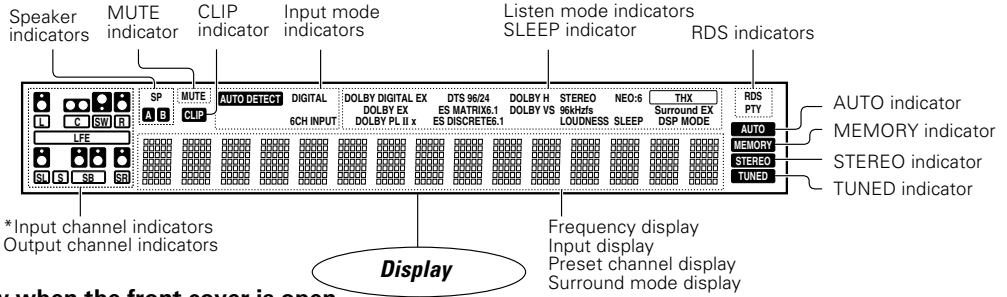

\* Input channel indicators  
Output channel indicators

The figure is the view when the front cover is open.

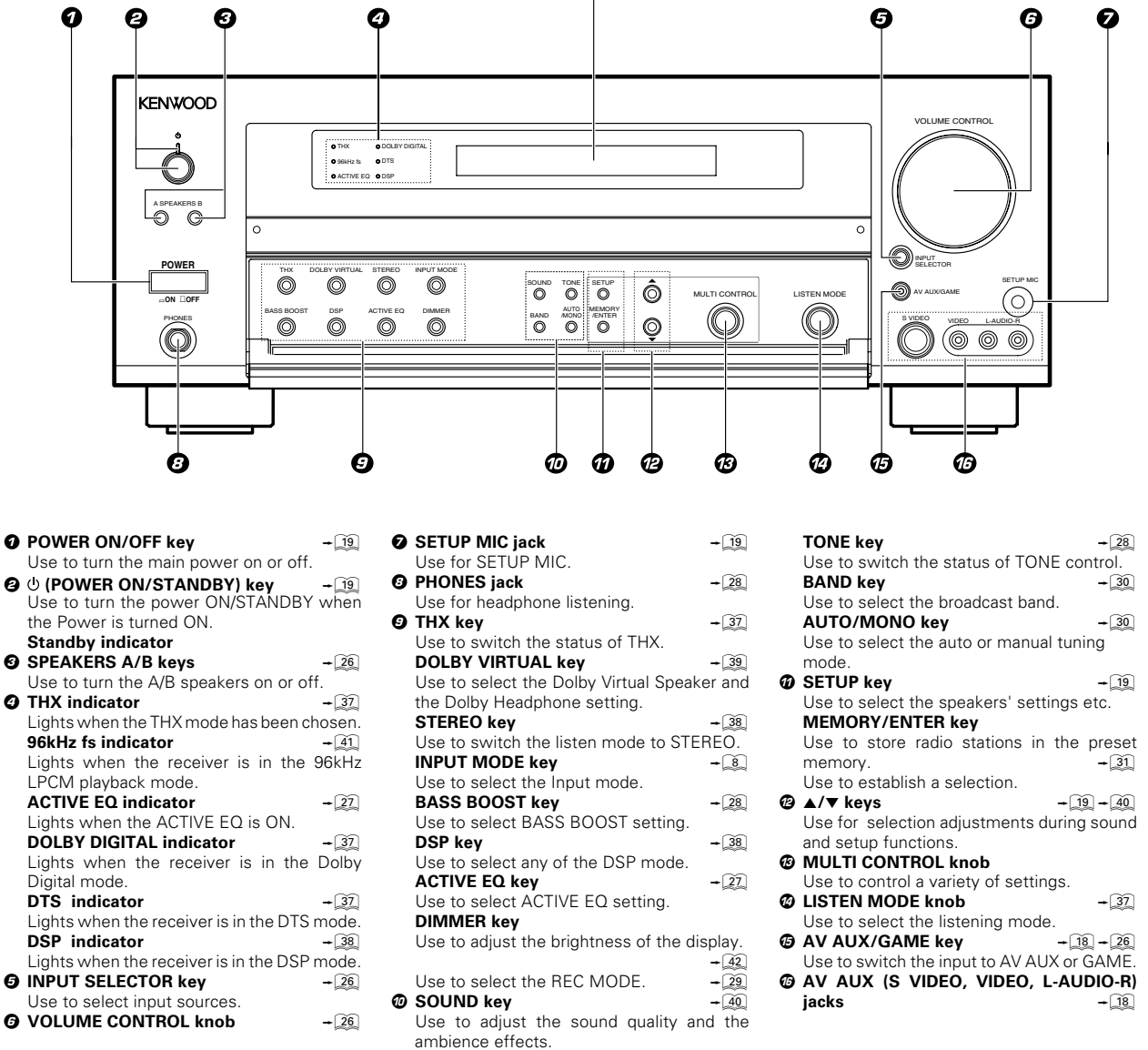

## Standby mode

While the standby indicator is lit, a small amount of power is supplied to the system to back up the memory. This is called standby mode. Under the condition, the system can be turned ON by remote control unit.

## Remote control unit

This remote control unit can be used not only for Kenwood products but also for other non-Kenwood products by setting the appropriate manufacturer's setup codes. → 43

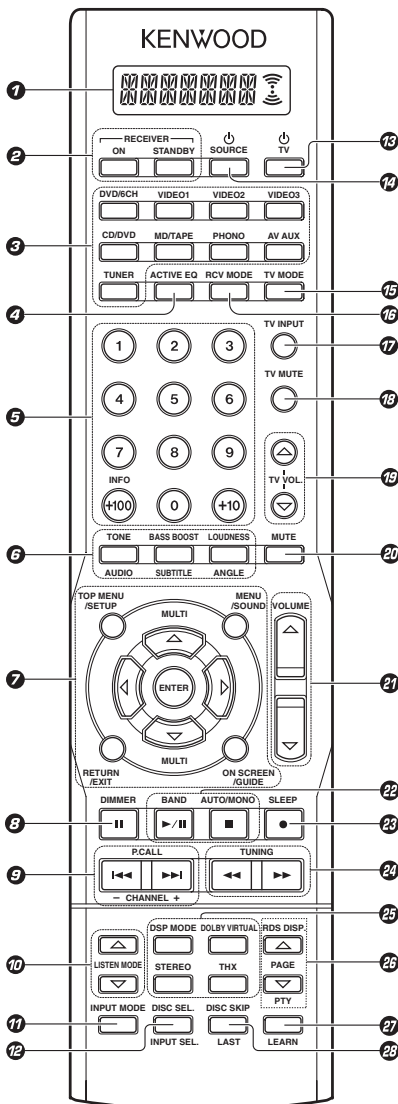

- 1 LCD (Liquid Crystal Display)** → 43  
Shows the operation mode of the remote control unit.
- 2 RECEIVER ON key** → 19  
Use to turn the receiver on.  
**RECEIVER STANDBY key**  
Use to turn the receiver off (standby).
- 3 Input Selector keys (DVD/6CH, VIDEO 1, VIDEO 2, VIDEO 3, CD/DVD, MD/TAPE, PHONO, AV AUX, TUNER)** → 26  
Used to select the input sources.  
**Source keys (DVD/6CH, VIDEO 1, VIDEO 2, VIDEO 3, CD/DVD, MD/TAPE, PHONO, AV AUX, TUNER)** → 43 - 45  
Use to select registered components.
- 4 ACTIVE EQ key** → 27  
Use to select ACTIVE EQ setting.
- 5 Numeric keys** → 43  
Use to input numeric characters.  
Use to select preset radio stations.  
Use to operate other components.
- 6 TONE key** → 28  
Use to switch the status of TONE control.  
**BASS BOOST key** → 28  
Use to select the maximum adjustment setting for the low frequency range.  
**LOUDNESS key** → 28  
Use to switch the status of LOUDNESS.  
**AUDIO key**  
**SUBTITLE key**  
**ANGLE key**  
Use to operate other components.
- 7 MULTI  $\Delta/\nabla/\leftarrow/\rightarrow$  keys** → 28  
Use to control a variety of settings.  
Use to operate other components.  
**TOP MENU key**  
**MENU key**  
**RETURN key**  
**EXIT key**  
**ON SCREEN key**  
**GUIDE key**  
Use to operate other components.  
**ENTER key**  
Use to establish a selection.  
Use to operate other components.
- 8 DIMMER key** → 42  
Use to adjust the brightness of the display.  
**II key**  
Use to operate other components.
- 9 P.CALL  $\leftarrow/\rightarrow$  keys** → 31  
Use for selection adjustments during sound, set up and preset channel functions.  
**CHANNEL  $-/+$  keys**  
Use to select the channels.
- 10 LISTEN MODE  $\Delta/\nabla$  keys** → 37  
Use to select the listening mode.
- 11 INPUT MODE key** → 8  
Use to select the Input mode.
- 12 DISC SEL. key**  
**INPUT SEL. key**  
Use to operate other components.
- 13 TV key**  
Use to turn the TV on or off.
- 14 SOURCE key**  
Use to turn the other source components on or off.
- 15 TV MODE key**  
Use to adjust the TV equipment.
- 16 RCV MODE key**  
Use to switch the remote control unit to the receiver control mode.
- 17 TV INPUT key**  
Use to select TV's input.
- 18 TV MUTE key**  
Use to temporarily mute the TV sound.
- 19 TV VOL.  $\Delta/\nabla$  keys**  
Use to adjust the TV's volume.
- 20 MUTE key** → 28  
Use to temporarily mute the sound.
- 21 VOLUME  $\Delta/\nabla$  keys** → 26  
Use to adjust the receiver's volume.
- 22 BAND key** → 30  
Use to select the broadcast band.  
**▶/II key**  
Use to operate the DVD, CD, MD or VCR component.  
**AUTO/MONO key** → 30  
Use to select the auto or manual tuning mode.  
**■ key**  
Use to operate the DVD, CD, MD or VCR component.
- 23 SLEEP key** → 42  
Use to set the Sleep timer.  
**● key**  
Use to operate the MD or VCR components.
- 24 TUNING  $\leftarrow/\rightarrow$  keys** → 30  
Use to tune the broadcast station.
- 25 DSP MODE key** → 38  
Use to select any of the DSP mode.  
**DOLBY VIRTUAL key** → 39  
Use to select the Dolby Virtual Speaker and the Dolby Headphone setting.  
**STEREO key** → 38  
Use to switch the listen mode to STEREO.
- 26 THX key** → 37  
Use to switch the status of THX.
- 27 PAGE  $\Delta/\nabla$  keys**  
Use to operate other components.
- 28 RDS DISP. key** → 32  
Use to receive RDS broadcast.
- 29 PTY key** → 33  
Use for PTY search.
- 30 LEARN key**  
Use to register other components. → 43  
Use to memorize the operation of the other remote code. → 45
- 31 DISC SKIP key**  
**LAST key**  
Use to operate other components.

# Setting up the system

Make connections as shown in the following pages. When connecting the related system components, be sure to refer to the instruction manuals supplied with the components you are connecting. Do not connect the power cord to a wall outlet until all connections are completed.

## Notes

1. Be sure to insert all connection cords securely. If their connections are imperfect, sound may not be produced or there will be noise interference.
2. Be sure to remove the power cord from the AC outlet before plugging or unplugging any connection cords. Plugging/unplugging connection cords without disconnecting the power cord can cause malfunctions and may damage the unit.

## CAUTION

Do not connect power cords from components whose power consumption is larger than what is indicated on the AC outlet at the rear of this unit.

## Analog connections

Audio connections are made using RCA pin cords. These cables transfer stereo audio signal in an "analog" form. This means the audio signal corresponds to the actual audio of two channels. These cables usually have 2 plugs on each end, one red for the right channel and one white for the left channel. These cables are usually packed together with the source unit, or are available at your local electronics retailer.

## Microcomputer malfunction

If operation is not possible or an erroneous display appears, even though all connections have been made properly, reset the microcomputer referring to "In case of difficulty". → 62

## Memory back up function

Please note that the following items will be deleted from the unit's memory if the power cord is disconnected from the AC outlet for approximately 1 day.

- |                             |                       |
|-----------------------------|-----------------------|
| • Power mode                | • Speaker settings    |
| • Input selector settings   | • Input mode setting  |
| • Speaker ON/OFF            | • Sound mode settings |
| • Volume level              | • Broadcast band      |
| • BASS, TREBLE, INPUT level | • Frequency setting   |
| • TONE ON/OFF               | • Preset stations     |
| • LOUDNESS ON/OFF           | • Tuning mode         |
| • Dimmer level              | • ACTIVE EQ mode      |
| • Listen mode setting       | • GAME mode setting   |

## CAUTION

The power in this equipment will not be completely cut off from the wall outlet when the power switch is turned off.

Install the equipment so that the wall outlet is easily accessible and, in case of emergency, immediately unplug the power cord from the wall outlet.

## Input mode settings

CD/DVD, VIDEO 2, VIDEO 3 and DVD/6CH inputs each include jacks for digital audio input and analog audio input.

The initial factory settings for audio signal playback for CD/DVD, DVD/6CH and VIDEO 2 and VIDEO 3 are FULL AUTO.

After completing connections and turning on this model, follow the steps below.

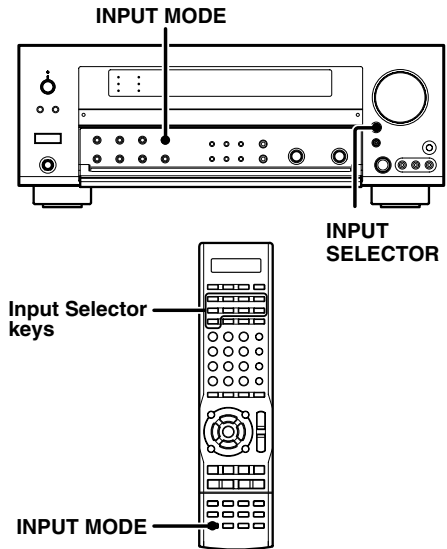

1 Use the INPUT SELECTOR key or Input Selector keys to select CD/DVD, VIDEO 2, VIDEO 3 or DVD/6CH.

2 Press the INPUT MODE key.

Each press switches the setting as follows:

### In DTS play mode

- 1 FULL AUTO (digital input, analog input)
- 2 DIGITAL MANUAL (digital input)

### In CD/DVD, VIDEO 2, VIDEO 3 or DVD/6CH play mode

- 1 FULL AUTO (digital input, analog input)
- 2 DIGITAL MANUAL (digital input)
- 3 6CH INPUT (DVD/6CH input only)
- 4 ANALOG (analog input)

### Auto detect:

In FULL AUTO mode ("AUTO DETECT" indicator lights up), the receiver detects the digital or analog input signals automatically. The receiver will select the input mode and listening mode automatically during playback to match the type of input signal (Dolby Digital, PCM, DTS) and the speaker setting. → 37

The "DIGITAL" indicator lights up when a digital signal is detected. The "DIGITAL" indicator is extinguished when no digital signal is detected.

### Fixed to digital input:

Select this mode if you want to keep the decoding condition (Dolby Digital, DTS, PCM, etc.) in the current listen mode.

When DIGITAL MANUAL mode is selected, the set listen modes may be changed automatically depending on the input signal. → 37

### Fixed to analog input:

Select this setting to play analog signals from a VCR, etc.

If the INPUT MODE key is pressed quickly, sound may not be produced. Press the INPUT MODE key again.

## Connecting the terminals

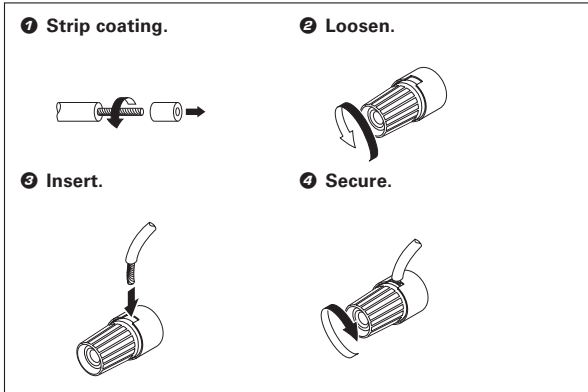

- Never short circuit the + and – speaker cords.
- If the left and right speakers are connected inversely or the speaker cords are connected with reversed polarity, the sound will be unnatural with ambiguous acoustic imaging. Be sure to connect the speakers correctly.

### Speaker impedance

After confirming the speaker impedance indications printed on the rear panel of this model, connect speakers with matching impedance ratings. Using speakers with a rated impedance other than that indicated on the rear panel of this model could result in malfunctions or damage to the speakers or this model.

### Speaker placement

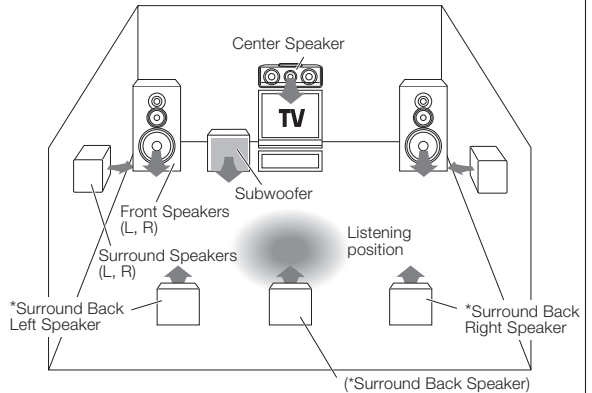

For optimum results, place the Surround Back speakers together for THX Select2 Cinema, THX MusicMode, and THX Games.

\* For Surround Back Speaker, you may place either two Surround Back Speakers (Surround Back Left Speaker and Surround Back Right Speaker) for 7.1 channel surround sound system or one Surround Back Speaker for 6.1 channel surround sound system.

#### Front (left and right) Speakers

Place at the front left and right of the listening position. Front speakers are required for all surround modes.

#### Center Speaker

Place front and center. This speaker stabilizes the sound image and helps recreate sound motion.

#### Surround (left and right) Speakers

Place at the direct left and right, or slightly behind, the listening position at even heights, approximately 1 meter above the ears of the listeners. These speakers recreate sound motion and atmosphere.

#### Subwoofer

Usually, place the subwoofer in the front center position in the listening room, near one of the front speakers near the center speaker. (Since the subwoofer has less directivity than other speakers, it can be placed almost in any position that can offer the best low frequency reproduction according to the room layout.)

#### Surround Back Speaker/s

Place the surround back speaker behind the listening position, at the same height as the left and right surround speakers.

- Although the ideal surround system consists of all the speakers listed above, if you don't have a center speaker or a subwoofer, you can divide those signals between the available speakers in the speaker settings steps to obtain the best possible surround reproduction from the speakers you have available.



## Connecting audio components

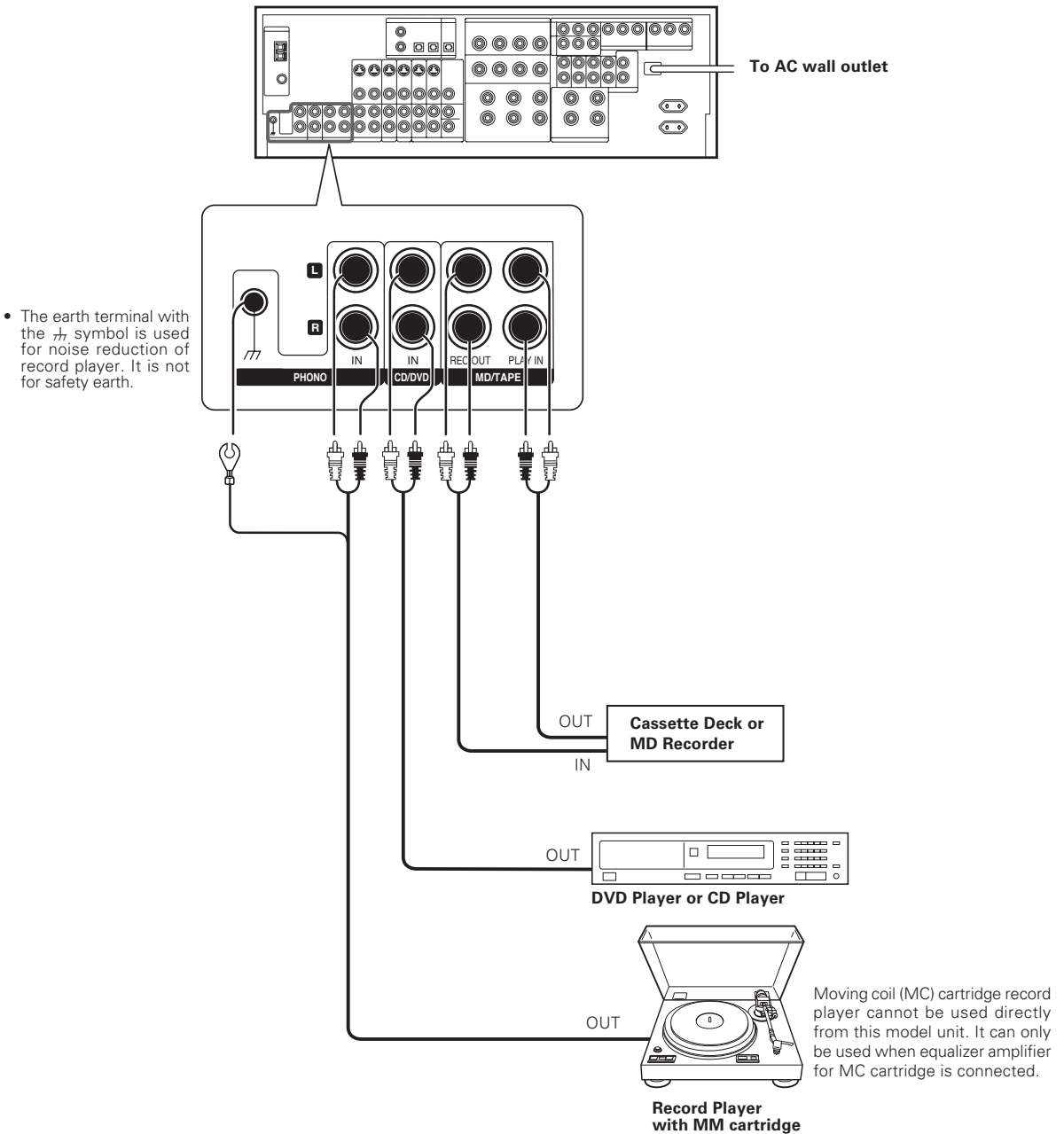

### CAUTION

Be sure to adhere to the following, or proper ventilation will be blocked causing damage or fire hazard.

- Do not place any object impairing heat radiation onto the top of the unit.
- Leave a space around the unit (from the largest outside dimension including projection) equal or greater than, shown below.

Top panel : 50 cm

Side panel : 10 cm

Back panel : 10 cm

## Connecting video components

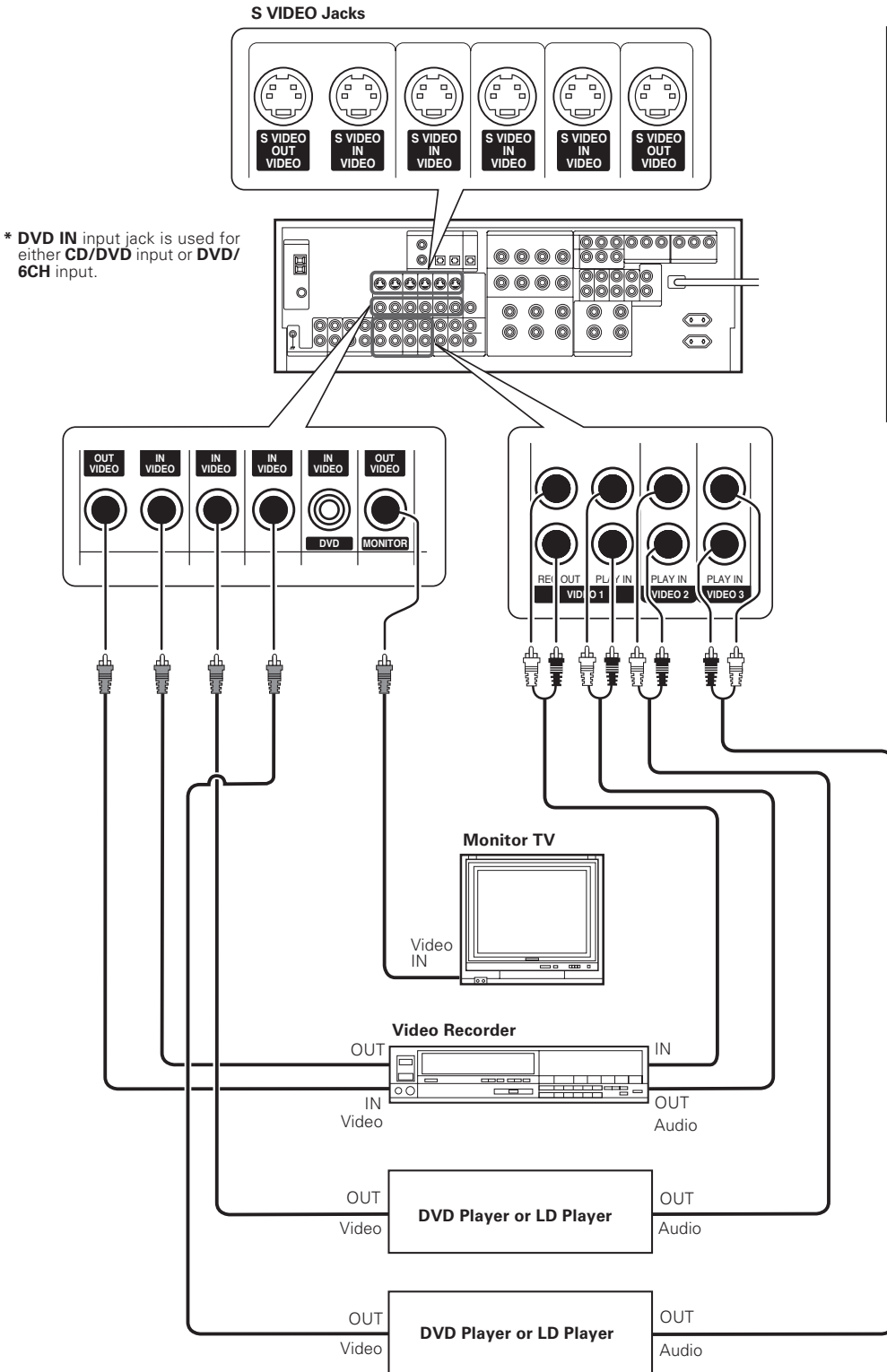

### About the S VIDEO Jacks

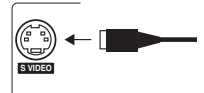

Use the S VIDEO Jacks to make connections to video components with S VIDEO IN/OUT Jacks.

- If you use the S VIDEO jacks to connect your video playback components, be sure to use the S VIDEO jacks when connecting your monitor and video recording components.

- A video component with digital audio outputs should be connected to the VIDEO 2 or VIDEO 3 jacks.
- For optimum video performance, THX recommends that video pass through (bypass) is used.

## Digital connections

The digital in jacks can accept DTS, Dolby Digital, or PCM signals. Connect components capable of outputting DTS, Dolby Digital, or standard PCM (CD) format digital signals.

If you have connected any digital components to this model, be sure to read the "Input mode settings" section carefully.

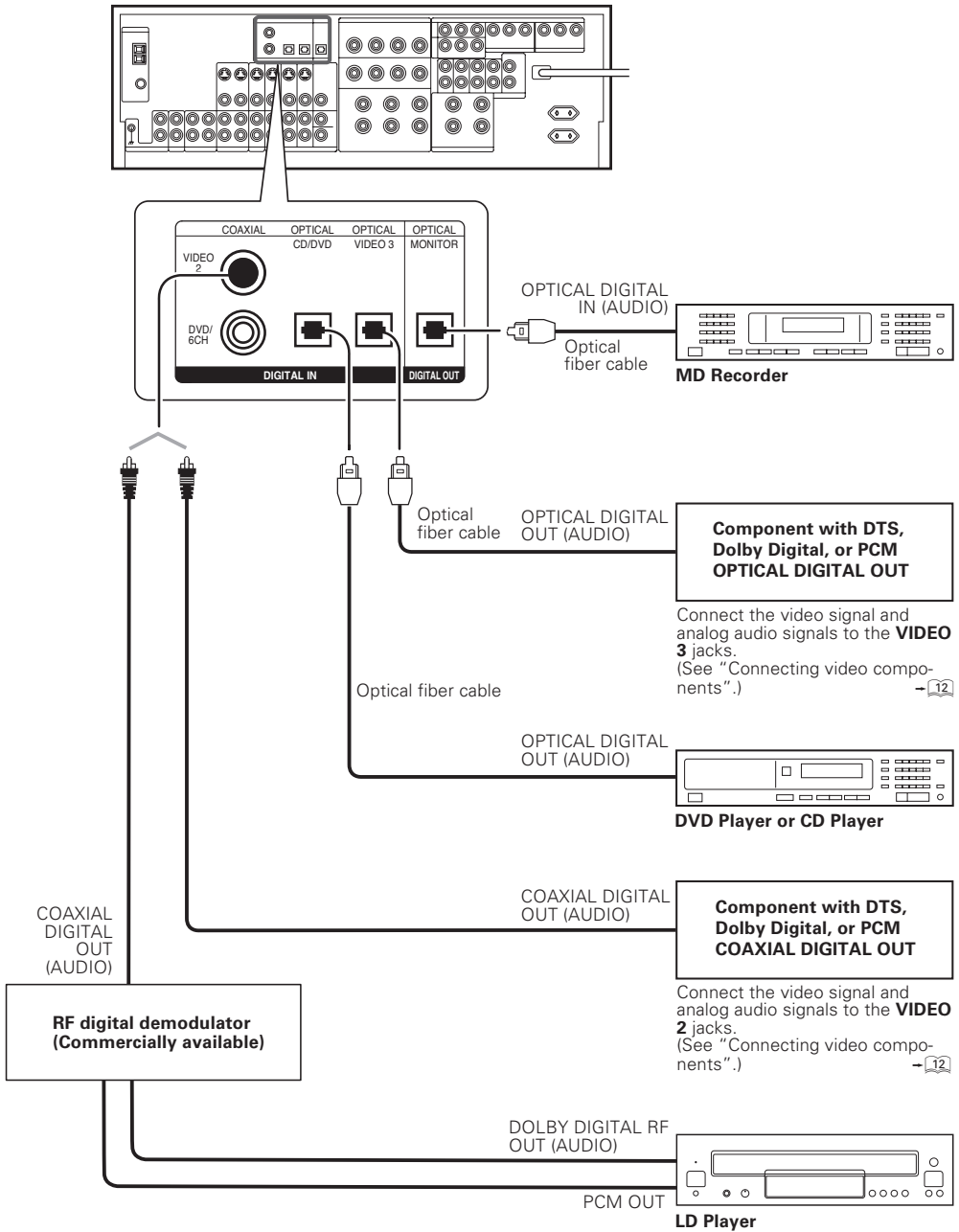

**Component with DTS, Dolby Digital, or PCM OPTICAL DIGITAL OUT**

Connect the video signal and analog audio signals to the **VIDEO 3** jacks. (See "Connecting video components".) → 12

**DVD Player or CD Player**

**Component with DTS, Dolby Digital, or PCM COAXIAL DIGITAL OUT**

Connect the video signal and analog audio signals to the **VIDEO 2** jacks. (See "Connecting video components".) → 12

**LD Player**

To connect an LD player with a DIGITAL RF OUT, connect the LD player to an RF digital demodulator (Commercially available). Next, connect the DIGITAL OUT jack of the demodulator to the DIGITAL IN jack of this model. Connect the video signal and analog audio signals to the VIDEO 2 or VIDEO 3 jacks. (See "Connecting video components".)

## Connecting video components (COMPONENT VIDEO)

If you have connected this model to a video component with COMPONENT jacks, you can get a better picture quality than by connecting to the S-VIDEO jacks.

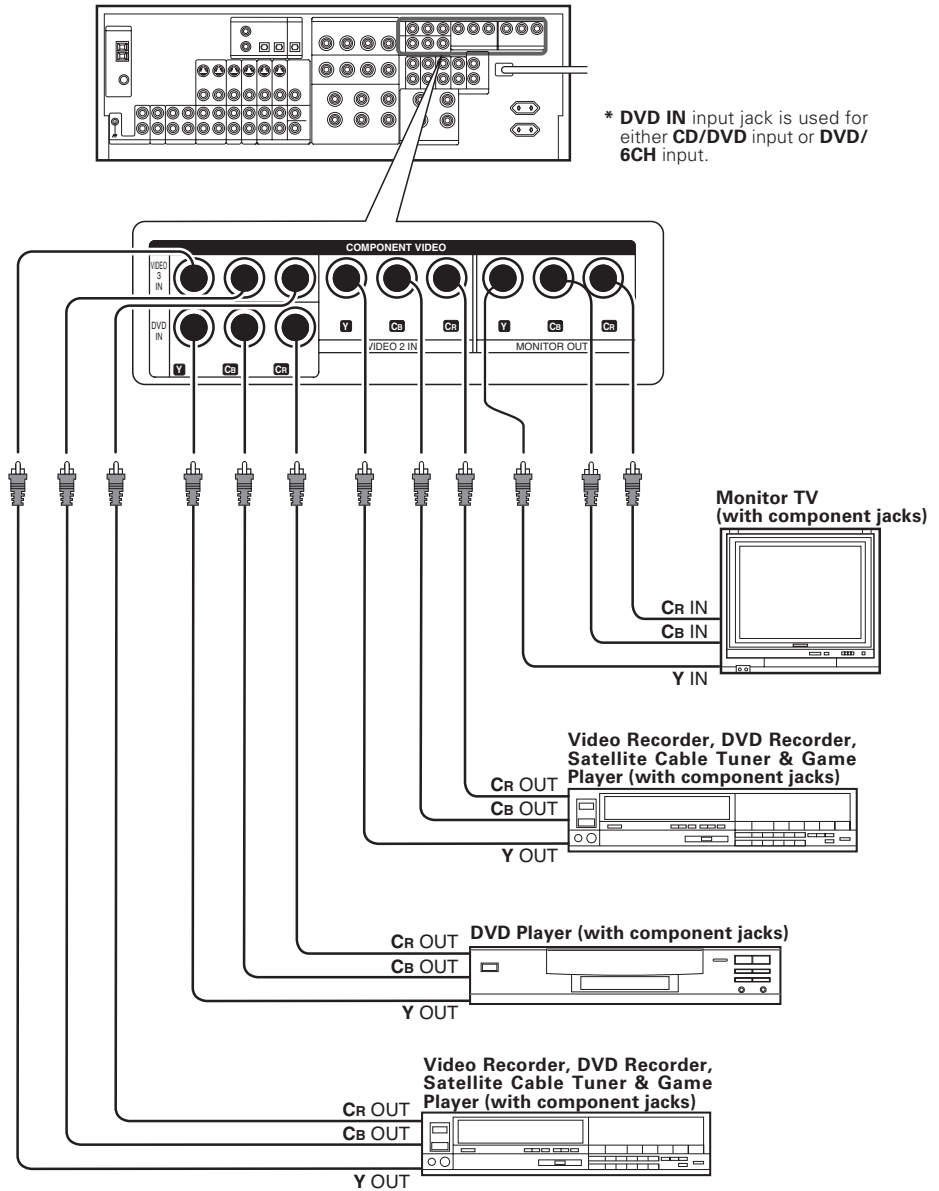

When connecting the TV to the COMPONENT jacks, be sure to connect all the other components to the COMPONENT jacks.

## Connecting the speakers

### Surround Back Speaker/s

When connecting a single Surround Back Speaker, connect it to SURROUND BACK L terminals and select "SB LARGEx1" or "SB NML/THXx1" at Speaker settings. → 23

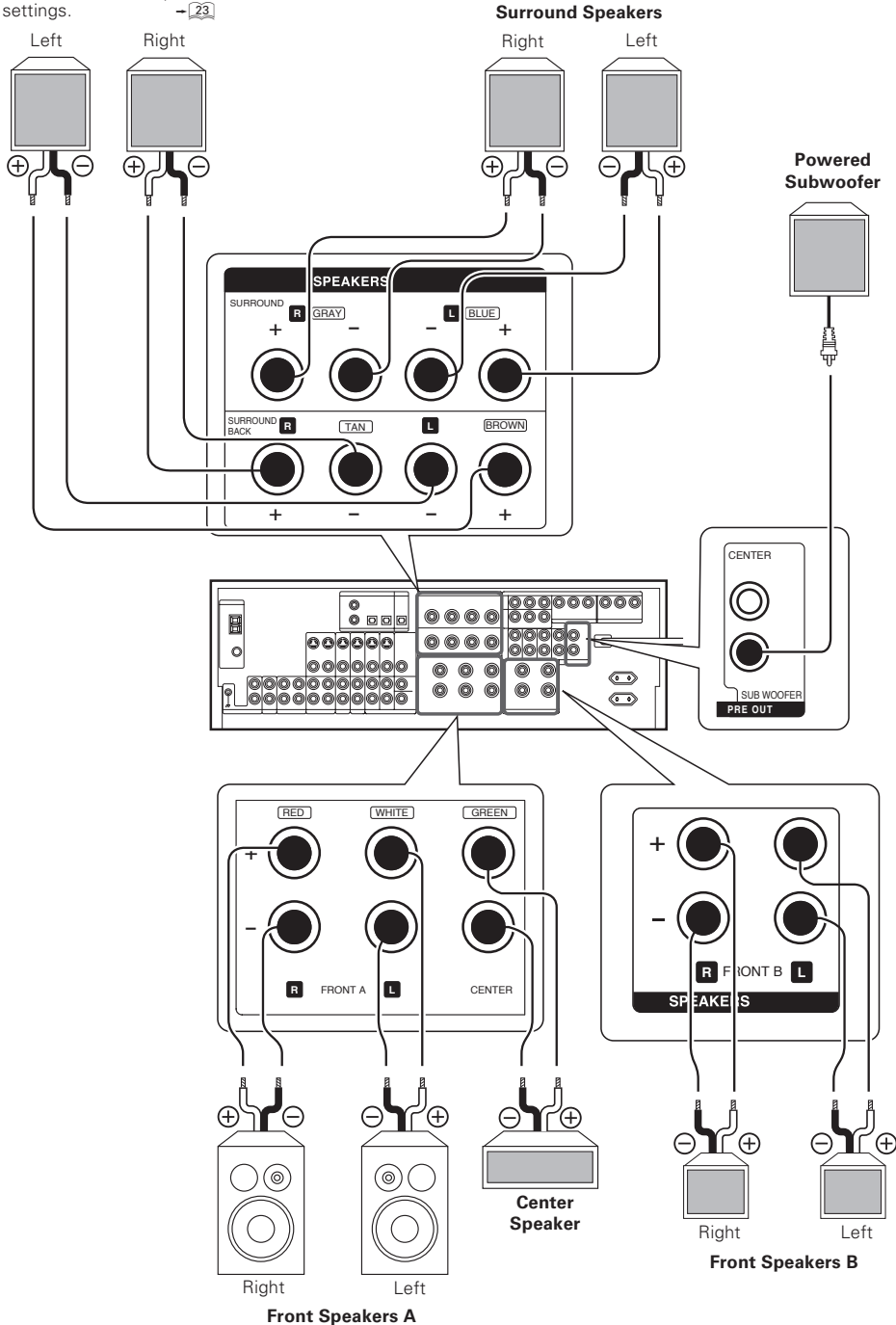

- To make sure that each speaker has been connected properly, pay attention to the test tone from each speaker. Refer to "Adjust the speaker volume level." → 23
- When you wish to connect the second pair of Front speakers or to connect the speakers in a different room to this unit, use the SPEAKERS FRONT B terminals for connection.

## PRE OUT connections

This receiver has additional **PRE OUT** jacks. These can be used for various purposes, but will need to be connected to an external power amplifier as shown in the example below.

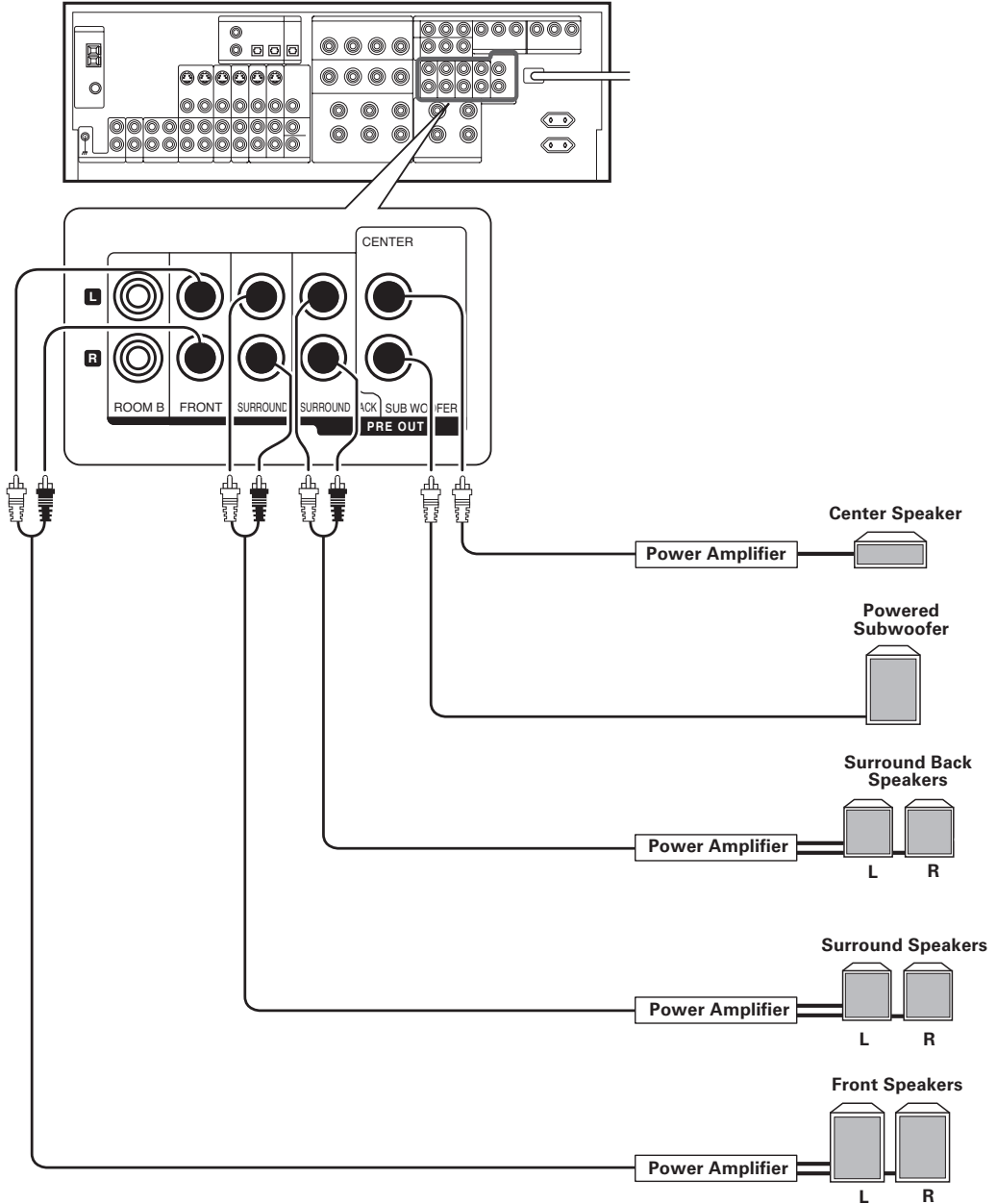

- Connecting a speaker cord directly to a **PRE OUT** jack will not produce any sound from the speaker.
- To use the **PRE OUT** jacks, press only the **SPEAKERS A** key to the ON position. — 26

## Connecting to another room (ROOM B)

This connection allows you to connect your main system to a monitor TV and speaker system located in another area (ROOM B).

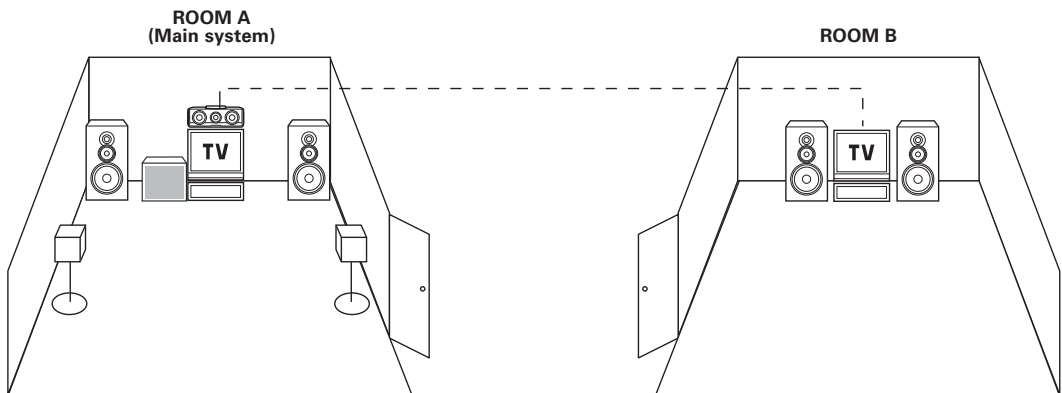
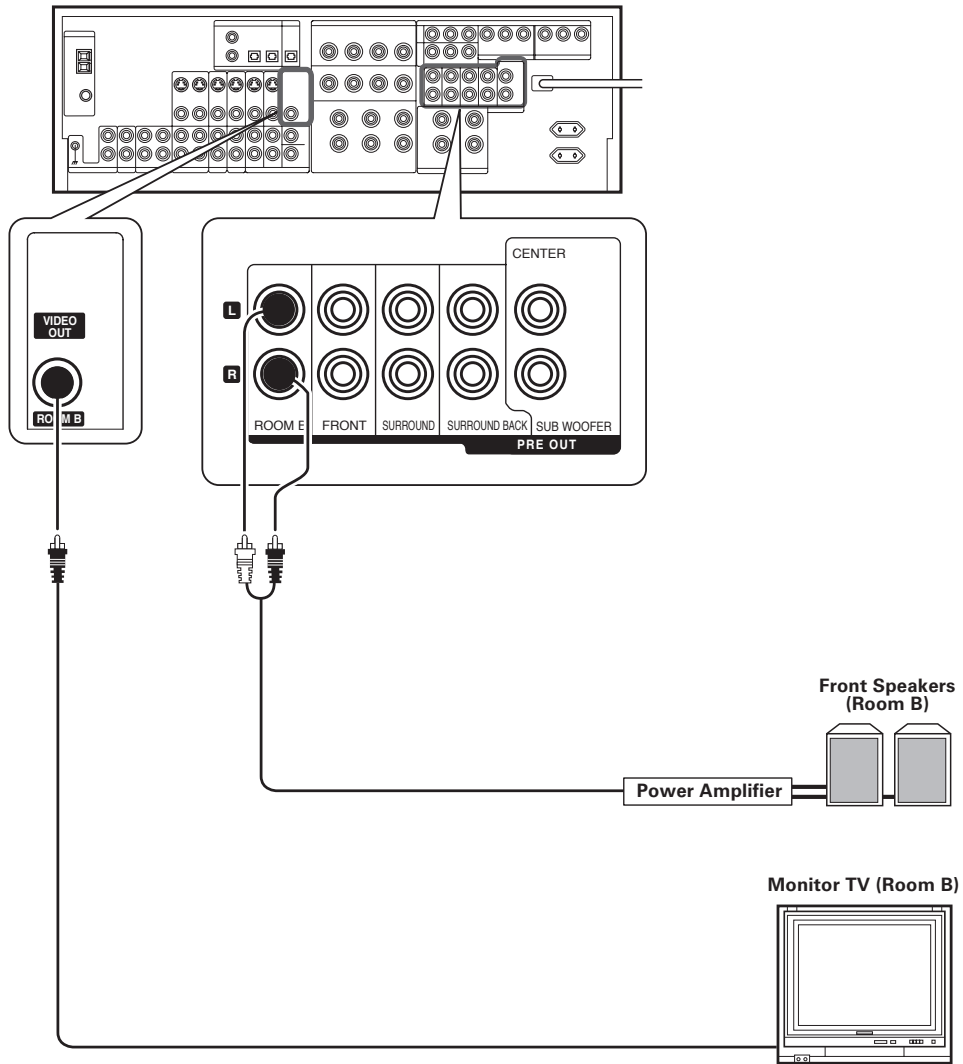

The sound from ROOM B PRE OUT jacks is the same as that of the Front Speakers.  
When listening in another room (ROOM B), set the LISTEN mode to STEREO. - [38]

## Connecting to the AV AUX jacks

The **AV AUX** jacks are convenient for connection of video components such as a camcorder or a video game.

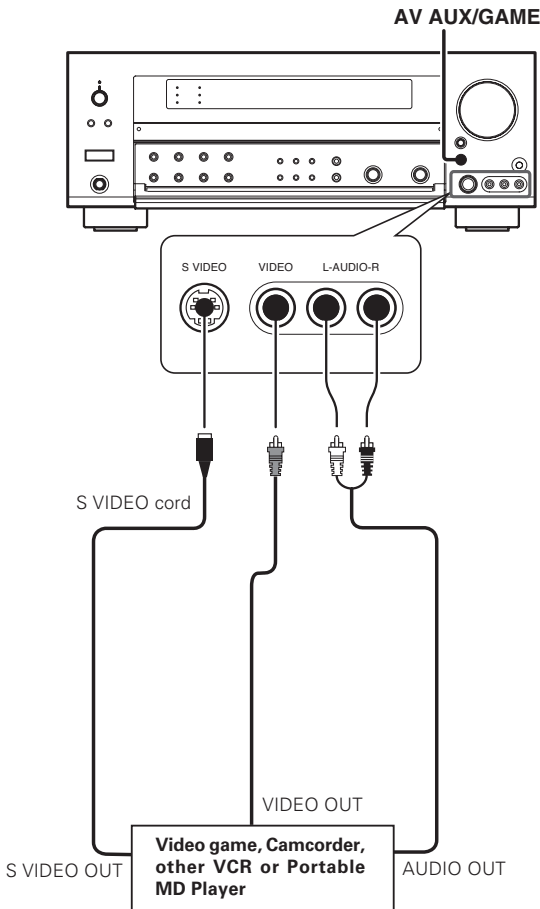

- This model has a game function which is convenient for using game equipment. It is recommended that the game equipment be connected to AV AUX jacks and the game mode be turned ON. — 26
- To select the source connected to the AV AUX jacks press AV AUX/GAME key. — 26
- When you connect the audio source such as the MD player, you do not need to connect the video cable.
- When you connect the component with the S VIDEO cord, you can get better picture quality.

## Connecting the antennas

The broadcast reception cannot be made unless the antennas are connected. Connect the antennas correctly as instructed below.

### AM Loop Antenna

Place the supplied loop antenna as far as possible from the receiver, TV set, speaker cords and power cord, and adjust the direction for best reception.

#### AM Antenna Terminal connections

- 1 Push lever.
- 2 Insert cord.
- 3 Release lever.



### FM Indoor Antenna

The supplied indoor antenna is for temporary use only. For stable signal reception we recommend using an outdoor antenna. Disconnect the indoor antenna when you connect one outdoors.

#### FM Antenna Terminal connections

Insert cord.



### FM Outdoor Antenna

Lead the 75Ω coaxial cable connected to the FM outdoor antenna into the room and connect it to the **75Ω FM** terminal.

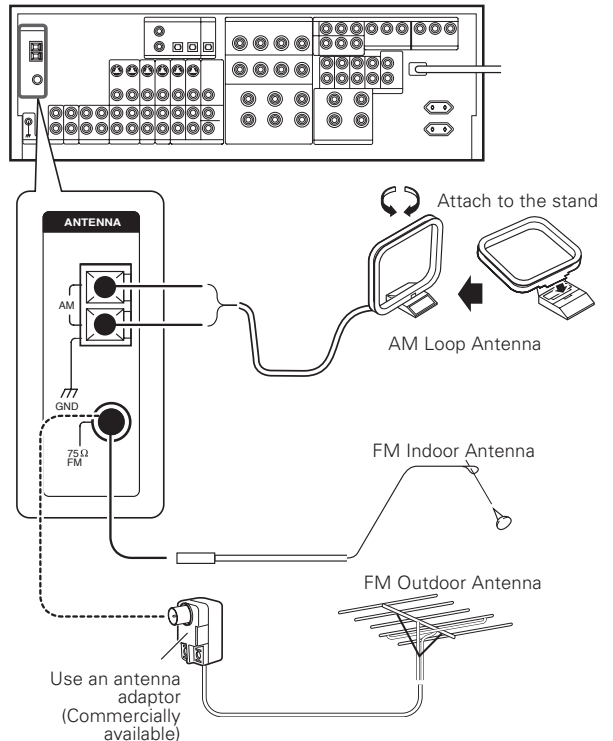

# Preparing for surround sound

## Before setting up the speakers

For the optimum surround playback, variety of speaker settings are necessary. Following the procedure below, go through the settings described in further pages.

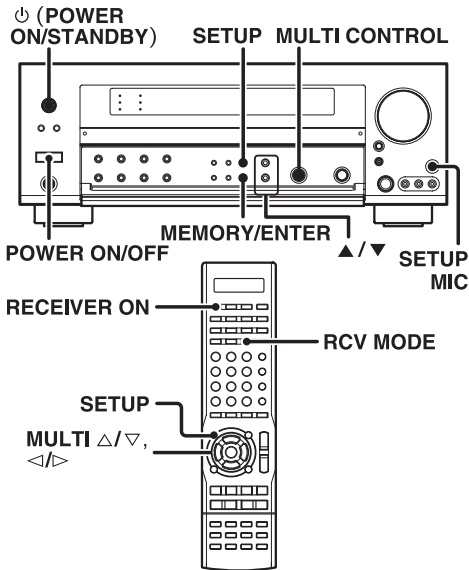

- 1** When performing "Setting up the speakers automatically (AUTO SETUP)", connect the provided microphone for setup to the SETUP MIC jack.
- 2** Turn on the power to this receiver by pressing the POWER ON/OFF key and (POWER ON/STANDBY) key, or RECEIVER ON key.
- 3** If you want to use the remote control unit, press the RCV MODE key on the remote control unit to set it to the receiver control mode.
- 4** Press the SETUP key to enter the SETUP mode. Use the Δ/∇ keys or MULTI </> keys for the following displays.

- ① AUTO SETUP
- ② MANUAL SETUP
- ③ SW RE-MIX
- ④ CROSSOVER
- ⑤ SB SPACING
- ⑥ BASS PEAK
- ⑦ LFE LEVEL
- ⑧ AUDIO DELAY
- ⑨ DISPLAY MODE
- ⑩ SETTING LOCK
- ⑪ EXIT

The flow of the SETUP is as follows:

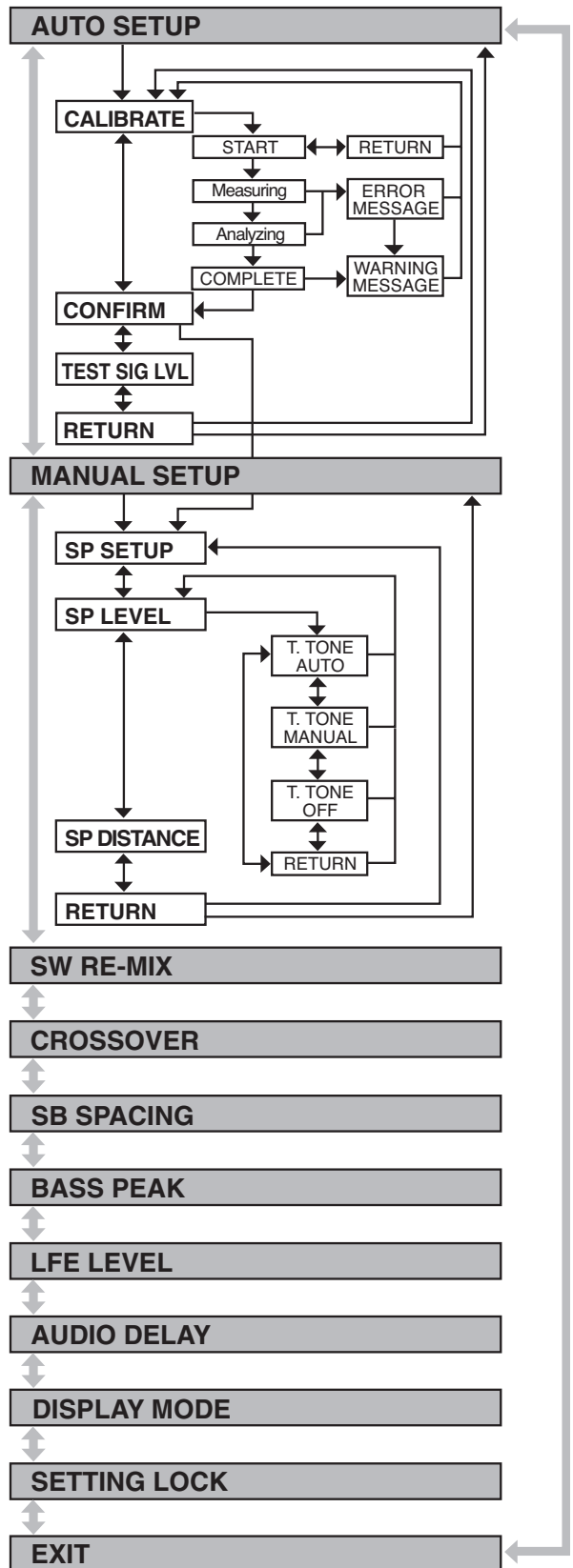

## Setting up the speakers automatically (AUTO SETUP) "Kenwood Room Acoustic Calibration"



A very loud test sound is produced during the measurement. Please take into consideration that it may disturb your neighborhood, especially, when you measure it at the night time.

"Kenwood Room Acoustic Calibration" function automatically performs the following adjustments with the provided microphone by measuring sound characteristics for the best listening environment according to your room conditions and speakers layout.

- ① Speaker presence and its size
- ② Volume level differences from each speaker
- ③ Sound delay from speakers
- ④ Room sound characteristics

### • Image of the measurement

Place the microphone at a height of your ears.

Do not place any obstacles between the microphone and speakers during the measurement.

The measurement may not be carried out properly because of speaking voice or other noise. Keep it down while measuring.

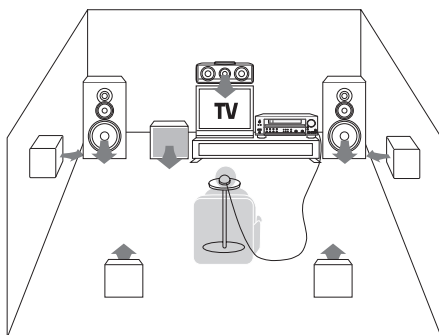

### 1 Perform automatic calibration.

- ① Use the  $\blacktriangle/\blacktriangledown$  keys or MULTI  $\triangleleft/\triangleright$  keys to select the "AUTO SETUP" and press the MEMORY/ENTER key or the ENTER key.
- ② Use the  $\blacktriangle/\blacktriangledown$  keys or MULTI  $\triangleleft/\triangleright$  keys to select the "CALIBRATE" and press the MEMORY/ENTER key or the ENTER key.
  - The display which indicates start of the measurement, "START" is displayed.
  - If you wish not to start measuring, use the  $\blacktriangle/\blacktriangledown$  keys or MULTI  $\triangleleft/\triangleright$  keys to select "RETURN", and then press the MEMORY/ENTER key or the ENTER key to return to "CALIBRATE" display.
- ③ Press the MEMORY/ENTER key or the ENTER key to start measuring.
  - The display which indicates during the measurement, "Measuring..." is displayed.
  - It takes about 2 minutes to complete the measurement.
  - If the provided microphone is not connected, "E01:No MIC" is displayed and no measurement is performed.
  - After the measurement is completed, analyzing starts and "Analyzing x/4" (x changes from 1 to 4) is displayed. When the analyzing is completed, "COMPLETE" will be shown for a few seconds, and changed to "CONFIRM".
  - Do not turn off the receiver while measuring. Otherwise, the measurement contents are changed back to the factory setting.

### 2 Exit the AUTO SETUP mode.

When "CONFIRM" is displayed, press the MEMORY/ENTER key or the ENTER key.

- The display which indicates the confirmation of the measurement contents, "SP SETUP" is displayed. - [22]
- Use the  $\blacktriangle/\blacktriangledown$  keys or MULTI  $\triangleleft/\triangleright$  keys to select "RETURN" while "CONFIRM" is displayed, and then press the MEMORY/ENTER key or the ENTER key to return to the "AUTO SETUP" display.

### Notes

- Sometimes due to the electrical complexities of subwoofers and the interaction with the room, THX recommends setting the level and the distance of the subwoofer manually.
- Sometimes due to interaction with the room, you may notice irregular results when setting the level and/or distance of the main speakers. If this happens, THX recommends setting them manually.
- Please note that any THX main speakers should be set to NML/THX (80Hz).  
If you set up your speakers using AUTO SETUP, please make sure manually that any THX speakers are set to NML/THX with 80Hz CROSSOVER.

### Test signal level adjustment

If a message such as "Exx : No Spk XX" or "Wxx : No Spk XX" is displayed even though each speaker is connected correctly, adjust the level of the test signal.

- ① While "CONFIRM" or "CALIBRATE" is displayed, use the  $\blacktriangle/\blacktriangledown$  keys or MULTI  $\triangleleft/\triangleright$  keys to select "TEST SIG LVL", and then press the MEMORY/ENTER key or the ENTER key.
- ② Use the MULTI CONTROL knob or MULTI  $\triangleleft/\triangleright$  keys to select a test signal level.
  - ① LEVEL LOW
  - ② LEVEL MID
  - ③ LEVEL HIGH
- ③ Press the MEMORY/ENTER key or the ENTER key to accept the setting.
- ④ Proceed to step ② of "1 Perform automatic calibration."

### Cancelling the measurement

If you operate any of the keys shown below, the measurement is cancelled and the display is return to the ordinary input display.

- ①  $\text{P}$  (POWER ON/STANDBY) key or RECEIVER STANDBY key
- ② VOLUME CONTROL knob or VOLUME  $\triangleleft/\triangleright$  keys
- ③ SETUP key
- ④ INPUT SELECTOR key

- If the measurement is cancelled, the measurement contents are changed back to the factory setting.

### About error messages

If the receiver detects some kind of problems while in calibration, an error message is shown in the display, and the processing is stopped. Eliminate the problem according to the message and try the calibration again. If there are more than one error messages, press the  $\blacktriangle/\blacktriangledown$  keys or MULTI  $\triangleleft/\triangleright$  keys to find the next one while the message is shown on the display. Press the MEMORY/ENTER key or the ENTER key to return to the "CALIBRATE" display.

E01 : No MIC
Microphone is not connected.
Connect the provided microphone for setup to the SETUP MIC jack.

E02 : Headphone
Headphones are being connected.
Disconnect the headphones.

E03 : No Spk FL
E04 : No Spk FR
Front Left (Right) speaker is not connected.
Connect a Front Left (Right) speaker.

E05 : No Spk SL
E06 : No Spk SR
Surround Right (Left) speaker is detected, but Surround Left (Right) speaker is not connected.
Connect a Surround Left (Right) speaker.

E07 : No SpkSBL
Surround Back Right speaker is detected, but Surround Back Left speaker is not connected.
For 7.1 channel system, connect a Surround Back Left speaker. For 6.1 channel system, reconnect the Surround Back Right speaker to SURROUND BACK L terminals.

E08 : SB w/o S
Surround Back speaker is detected, but Surround Left and Right speakers are not connected.
Connect Surround Left and Right speakers.

E09 : MIC clip
Microphone detects a large volume signal.
Do not touch or shake the microphone, and try the calibration again.

E10 : VolChange
Volume is changed while calibrating.
Do not change the volume while in calibration.

E99 : Error
Communication error occurred in the unit.
Try the calibration again. If the same message appears, consult your dealer.

### **About the warning messages**

Even if "**COMPLETE**" is shown on the display for several seconds and the calibration is completed, a warning message may appear if some kind of minor problems are detected.

Eliminate the problem according to the message and try the calibration again, or understand the problem and finish up the **AUTO SETUP**.

- If there are more than one warning messages, press the ▲/▼ keys or **MULTI** </> keys to find the next one while the message is shown on the display.
- Pressing the **MEMORY/ENTER** key or the **ENTER** key changes back the display to "**CALIBRATE**".
- Depending on the speakers, warning messages may appear even if the speakers are connected correctly. In this case, it is not problems.

W01 : Phase F
The connection of either Front Left or Right speaker is not correct (+ - inversion).
Make sure the + and - speaker cords are connected correctly for Front Left and Right speakers.

W02 : Phase S
The connection of either Surround Left or Right speaker is not correct (+ - inversion).
Make sure the + and - speaker cords are connected correctly for Surround Left and Right speakers.

W03 : Phase SB
The connection of either Surround Back Left or Right speaker is not correct (+ - inversion).
Make sure the + and - speaker cords are connected correctly for Surround Back Left and Right speakers.

W04 : No Spk C
Center speaker is not connected.
Connect a Center speaker if you have one. If there is no Center speaker, no need to connect it.

W05 : No SW
Subwoofer is not connected.
Connect a Subwoofer if you have one. If there is no Subwoofer, no need to connect it.

W06 : No Spk S
Surround speakers are not connected.
Connect a pair of Surround speakers if you have a set.
If there are no Surround speakers, no need to connect it.

W07 : No Spk SB
Surround Back speakers are not connected.
Connect a pair of Surround Back speakers if you have a set.
If there are no Surround Back speakers, no need to connect it.

W08 : No SpkSBR
Surround Back Right speaker is not connected.
Connect a Surround Back Right speaker if you have one.
If there is no Surround Back Right speaker, no need to connect it.

## Setting up the speakers manually (MANUAL SETUP)

### 1 Select a speaker system.

If you have THX certified speakers, please set them to NML/THX.

- 1 Press the ▲/▼ keys or MULTI </> keys to select the "MANUAL SETUP" and press the MEMORY/ENTER key or the ENTER key.
- 2 Select the "SP SETUP" and press the MEMORY/ENTER key or the ENTER key again so that the subwoofer setting indication "SUBW ON" appears.

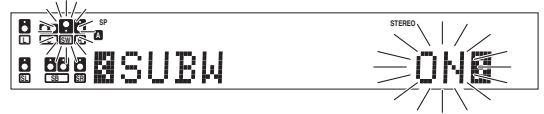

### 3 Use the MULTI CONTROL knob or MULTI ▲/▼ keys to select the appropriate subwoofer setting.

- 1 **SUBW ON** : A Subwoofer is connected to the receiver.
  - 2 **SUBW OFF** : A Subwoofer is not connected to the receiver.
- The initial setting is "SUBW ON".
  - When Subwoofer output sound is required, select "FRNT NML/THX", or select both "FRNT LARGE" and "SW RE-MIX ON".

### 4 Press the ▲ key or MULTI ▷ key to accept the setting.

- When the setting "SUBW ON" is selected, the front speakers setting indication "FRNT" appears.
- When the setting "SUBW OFF" is selected, the Front Speakers are automatically set to "FRNT LARGE" and the procedure skips to step 2.



### 5 Use the MULTI CONTROL knob or MULTI ▲/▼ keys to select the appropriate front speakers setting.

- 1 **FRNT NML/THX** : Average size Front Speakers are connected to the receiver.
- 2 **FRNT LARGE** : Large size Front Speakers are connected to the receiver.

### 6 Press the ▲ key or MULTI ▷ key to accept the setting.

- The Center Speaker setting indication "CNTR" appears.

### 7 Use the MULTI CONTROL knob or MULTI ▲/▼ keys to select the appropriate Center Speaker setting.

If you selected "FRNT LARGE" as the Front Speakers setting,

- 1 **CNTR NML/THX** : An average size Center Speaker is connected to the receiver.
- 2 **CNTR LARGE** : A large size Center Speaker is connected to the receiver.
- 3 **CNTR OFF** : A Center Speaker is not connected to the receiver.

If you selected "FRNT NML/THX" as the Front Speakers setting,

- 1 **CNTR NML/THX** : An average size Center Speaker is connected to the receiver.
- 2 **CNTR OFF** : A Center Speaker is not connected to the receiver.

### 8 Press the ▲ key or MULTI ▷ key again to accept the setting.

- The Surround Speaker setting indication "SURR" appears.

- ⑨ Use the **MULTI CONTROL** knob or **MULTI**  $\Delta/\nabla$  keys to select the appropriate **Surround Speaker** setting.

If you selected “**FRNT LARGE**” as the **Front Speaker** setting,

- ① **SURR NML/THX** : Average size Surround Speakers are connected to the receiver.
- ② **SURR LARGE** : Large size Surround Speakers are connected to the receiver.
- ③ **SURR OFF** : Surround Speakers are not connected to the receiver.

If you selected “**FRNT NML/THX**” as the **Front Speaker** setting,

- ① **SURR NML/THX** : Average size Surround speakers are connected to the receiver.
- ② **SURR OFF** : Surround Speakers are not connected to the receiver.

- ⑩ Press the **▲** key or **MULTI**  $\triangleright$  key again to accept the setting.

- When the setting other than “**SURR OFF**” is selected, the Surround Back Speaker setting indication “**SB**” appears.
- When the setting “**SURR OFF**” is selected, the procedure skips to step ⑫.

- ⑪ Use the **MULTI CONTROL** knob or **MULTI**  $\Delta/\nabla$  keys to select appropriate **Surround Back Speaker** setting.

If you selected “**SURR LARGE**” as the **Surround Speaker** setting,

- ① **SB NML/THXx1** : A single average size Surround Back Speaker is connected to the receiver.
- ② **SB NML/THXx2** : A pair of average size Surround Back Speakers are connected to the receiver.
- ③ **SB LARGEx1** : A single large size Surround Back Speaker is connected to the receiver.
- ④ **SB LARGEx2** : A pair of large size Surround Back Speakers are connected to the receiver.
- ⑤ **SB OFF** : Surround Back Speakers are not connected to the receiver.



If you selected “**SURR NML/THX**” as the **Surround Speaker** setting,

- ① **SB NML/THXx1** : A single average size Surround Back Speaker is connected to the receiver.
- ② **SB NML/THXx2** : A pair of average size Surround Back Speakers are connected to the receiver.
- ③ **SB OFF** : Surround Back Speakers are not connected to the receiver.

- ⑫ Press the **MEMORY/ENTER** key or the **ENTER** key to return to the “**SP SETUP**” display.

## 2 Adjust the speaker volume level.

If you have a commercially available sound pressure meter, set the meter readout to “C” at the listening position and adjust the sound volume of each channel so that the noise level will reach 75dB. If you do not have a sound pressure meter, start the volume level from 0db and adjust so that the level from each speaker is almost the same.

- Indicators appear only for the channels of the speakers selected in step ⑦.

Be aware that the **TEST TONE** is quite a loud sound (0dB).

- ① Press the **▲/▼** keys or **MULTI**  $\triangleleft/\triangleright$  keys to select the “**SP LEVEL**” and press the **MEMORY/ENTER** key or the **ENTER** key.

- ② Press the **▲/▼** keys or **MULTI**  $\triangleleft/\triangleright$  keys for the following displays:

- ① **T.TONE AUTO** : Adjust the volume level from each speaker by using test tone. Test tone will be output from each speaker in order.
- ② **T.TONE MANUAL** : Adjust the volume level from each speaker by using test tone.
- ③ **T.TONE OFF** : Adjust the volume level from each speaker without using test tone.
- ④ **RETURN** : Press the **MEMORY/ENTER** key or the **ENTER** key to return to the “**SP LEVEL**” display.

- ③ After selecting “**T.TONE AUTO**” or “**T.TONE MANUAL**”, press the **MEMORY/ENTER** key or the **ENTER** key to begin **TEST TONE**.

Use the **MULTI CONTROL** knob or **MULTI**  $\Delta/\nabla$  keys to adjust the volume level of the test tone output from the speaker channel to be adjusted.

For **T.TONE AUTO** selection, the test tone is heard from the speakers in the following sequence for 2 seconds each starting from the **Front Left** speaker.

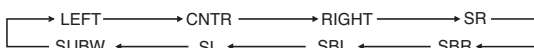

- If you have selected “**SB NML/THXx1**” or “**SB LARGEx1**”, “**SBR**” and “**SBL**” are not appeared but “**SB**” is appeared on the Display.

The channel indication blinks while the test tone is being output.



- If the speaker setting selects are **OFF**, the speaker level settings are reset.

For “**T.TONE MANUAL**” selection, press the **▲/▼** keys or **MULTI**  $\triangleleft/\triangleright$  keys each time to select the speaker channel.

If “**T.TONE OFF**” is selected, test tone is not output. Adjust the volume level from each speaker by listening the selected input source. → 26

- ④ Press the **MEMORY/ENTER** key or the **ENTER** key to return to the “**SP LEVEL**” display.

- The test tone is turned off and return to the main setup displays.

## 3 Input the distance to the speakers.

- Indicators appear only for the channels of the speakers selected in step ⑦.

- ① Press the **▲/▼** keys or **MULTI**  $\triangleleft/\triangleright$  keys to select the “**SP DISTANCE**” and press the **MEMORY/ENTER** key or the **ENTER** key.

- ② Use the **▲/▼** keys or **MULTI**  $\triangleleft/\triangleright$  keys to select a unit in distance and press the **MEMORY/ENTER** key or the **ENTER** key.

- ① **UNIT meters**
- ② **UNIT feet**
- ③ **RETURN** : Press the **MEMORY/ENTER** key or the **ENTER** key to return to the “**SP DISTANCE**” display.

- Measure the distance from the listening position to each of the speakers.

**Jot down the distance to each of the speakers.**

Distance to Front Left Speaker (L) : \_\_\_ meters (feet)  
 Distance to Center Speaker (C) : \_\_\_ meters (feet)  
 Distance to Front Right Speaker (R) : \_\_\_ meters (feet)  
 Distance to Surround Right (SR) : \_\_\_ meters (feet)  
 Distance to Surround Back Right (SBR) : \_\_\_ meters (feet)  
 Distance to Surround Back (SB) : \_\_\_ meters (feet)  
 Distance to Surround Back Left (SBL) : \_\_\_ meters (feet)  
 Distance to Surround Left (SL) : \_\_\_ meters (feet)  
 Distance to Subwoofer (SW) : \_\_\_ meters (feet)

- If you have selected "SB NML/THXx1" or "SB LARGEx1", "SBR" and "SBL" are not appeared but "SB" is appeared on the Display.

- Use the ▲/▼ keys or MULTI </> keys to select the speakers and the MULTI CONTROL knob or MULTI Δ/▽ keys to adjust the distance to the Front Speakers.

The speaker indicator to be adjusted blinks.

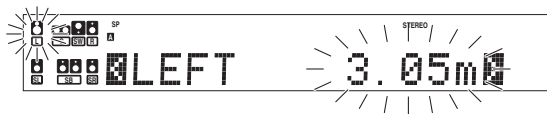

Indication in meters

- The allowable setting range is 0.03 to 9.14 meters (0.1 to 30.0 feet), adjustable in about 0.03 meters (0.1 foot) increments.

- Repeat steps 4 to input the distance for each of the speakers.

- Press the MEMORY/ENTER key or the ENTER key to return to the "SP DISTANCE" display.

- The speakers you have selected should appear on the display. Confirm that all the speakers have been correctly selected.

#### 4 Exit the MANUAL SETUP mode.

- Press the ▲/▼ keys or MULTI </> keys to select the "RETURN"



- Press the MEMORY/ENTER key or the ENTER key to return to the "MANUAL SETUP" display.

## Other settings

### 1 Adjust the Subwoofer RE-MIX.

- Press the ▲/▼ keys or MULTI </> keys to select the "SW RE-MIX" and press the MEMORY/ENTER key or the ENTER key.

- Use the MULTI CONTROL knob or MULTI Δ/▽ keys to select the appropriate Subwoofer re-mix setting.

If "SW RE-MIX ON" is selected as the subwoofer re-mix setting, the low frequencies are enhanced by adding the low frequencies of other channels to the subwoofer channel depending on the speaker setup.

- SW RE-MIX ON : Subwoofer re-mix setting mode to the receiver is ON.
- SW RE-MIX OFF : Subwoofer re-mix setting mode to the receiver is OFF.

- If Subwoofer is turned off or "FRNT NML/THX" is selected at the Front Speaker setting, Subwoofer re-mix setting is not visible.
- By selecting "SW RE-MIX OFF", the low frequencies will play through the Front Speakers only. This selection is preferred by THX.

- Press the MEMORY/ENTER key or the ENTER key to accept the setting.

### 2 Select the CROSSOVER frequency.

CROSSOVER function is to adjust the receiver's audio output characteristics with the speakers' characteristics which differs depending on the size of the speakers. You will be able to enjoy a more natural and dynamic sound experience even with small size speakers.

- Press the ▲/▼ keys or MULTI </> keys to select the "CROSS OVER" and press the MEMORY/ENTER key or the ENTER key.

- CROSSOVER function will not be available when "LARGE" is selected for all the speakers in step 1 and "SW RE-MIX OFF" is selected. → 22

- Use the MULTI CONTROL knob or MULTI Δ/▽ keys to select the CROSSOVER frequency.

- FREQ. : 40Hz
- FREQ. : 60Hz
- FREQ. : 80Hz-THX
- FREQ. : 100Hz
- FREQ. : 120Hz
- FREQ. : 150Hz

- If you have THX certified speakers, select "FREQ.:80Hz-THX".



- Press the MEMORY/ENTER key or the ENTER key to accept the setting.

### 3 Adjust the distance between left and right Surround Back speaker.

This mode is available only when "SB NML/THXx2" or "SB LARGEx2" has been selected in Surround Back Speaker setting.

- Press the ▲/▼ keys or MULTI </> keys to select the "SB SPACING" and press the MEMORY/ENTER key or the ENTER key.

2 Use the **MULTI CONTROL** knob or **MULTI**  $\Delta/\nabla$  keys to select the distance between left and right Surround Back speaker.

- 1 **TOGETHER** : The distance is 0.3 meters (1 foot) or less.
- 2 **CLOSE** : The distance is between 0.3 meters (1 foot) and 1.2 meters (4 feet).
- 3 **APART** : The distance is 1.2 meters (4 feet) or more.

3 Press the **MEMORY/ENTER** key or the **ENTER** key to accept the setting.

#### 4 Adjust the bass peak level.

A restriction is put on the low frequency so that the bass peak level will not go higher than the acceptable level when the volume is increased.

If Subwoofer is OFF, the limitation will affect the low frequency of the Front Left and Right Speakers.

1 Press the  $\Delta/\nabla$  keys or **MULTI**  $\langle/\rangle$  keys to select the “**BASS PEAK**” and press the **MEMORY/ENTER** key or the **ENTER** key.

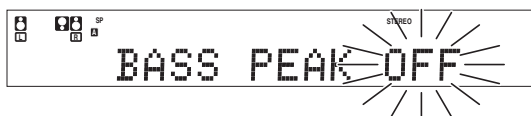

2 Use the **MULTI CONTROL** knob or **MULTI**  $\Delta/\nabla$  keys to adjust the bass peak level to **-30dB**.

- The adjustment range is from -30dB to 0dB and OFF.

3 For optimum bass peak level, keep increasing the bass peak level by using the **MULTI CONTROL** knob or **MULTI**  $\Delta/\nabla$  keys while test tone is being output until clip sound is heard from the Subwoofer or Front Speaker.



4 Press the **MEMORY/ENTER** key or the **ENTER** key to accept the setting.

#### 5 Adjust the LFE LEVEL (Low Frequency Effects).

1 Press the  $\Delta/\nabla$  keys or **MULTI**  $\langle/\rangle$  keys to select the “**LFE LEVEL**” and press the **MEMORY/ENTER** key or the **ENTER** key.

2 Use the **MULTI CONTROL** knob or **MULTI**  $\Delta/\nabla$  keys to adjust the **LFE LEVEL**.



- The **LFE LEVEL** can be adjusted from 0dB to -10dB in 1dB decrements.

3 Press the **MEMORY/ENTER** key or the **ENTER** key to accept the setting.

#### 6 Adjust the AUDIO DELAY.

Depending on video equipments, because of its internal processing moving image on the Monitor may seem to be delayed compared to the audio from the speakers. This can be adjusted by audio delay which delays audio to match the video picture.

1 Press the  $\Delta/\nabla$  keys or **MULTI**  $\langle/\rangle$  keys to select the “**AUDIO DELAY**” and press the **MEMORY/ENTER** key or the **ENTER** key.



2 Use the **MULTI CONTROL** knob or **MULTI**  $\Delta/\nabla$  keys to select the delay time.

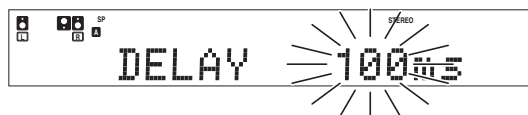

- The allowable setting range is 0 to 200 ms, adjustable in 10 ms increments.
- Delay is not applied when **TUNER**, **MD/TAPE**, **PHONO** or **6CH INPUT** is selected as an input, or **AUTO REC MODE** or **MANUAL REC MODE** is selected.
- When in 96kHz fs signal playback, the effectable delay time is up to 100ms.

3 Press the **MEMORY/ENTER** key or the **ENTER** key to accept the setting.

#### 7 Select the display mode.

1 Press the  $\Delta/\nabla$  keys or **MULTI**  $\langle/\rangle$  keys to select the “**DISPLAY MODE**” and press the **MEMORY/ENTER** key or the **ENTER** key.

2 Use the **MULTI CONTROL** knob or **MULTI**  $\Delta/\nabla$  keys to select the display mode.

- 1 **DISP SELECTOR** : Displays the current input selector.
- 2 **DISP LISTEN** : Displays the current listen mode or THX mode.



3 Press the **MEMORY/ENTER** key or the **ENTER** key to accept the setting.

#### 8 Lock the settings.

In case that the keys are mistakenly pressed, the setting can be locked.

1 Press the  $\Delta/\nabla$  keys or **MULTI**  $\langle/\rangle$  keys to select the “**SETTING LOCK**” and press the **MEMORY/ENTER** key or the **ENTER** key.

2 Use the **MULTI CONTROL** knob or **MULTI**  $\Delta/\nabla$  keys to select the lock mode.

- 1 **SETUP LOCKED** : Lock the settings.
- 2 **SETUP UNLOCKED** : Unlock the settings.

3 Press the **MEMORY/ENTER** key or the **ENTER** key to accept the setting.

#### 9 Exit the SETUP mode.

1 Press the  $\Delta/\nabla$  keys or **MULTI**  $\langle/\rangle$  keys to select the “**EXIT**”.



2 Press the **MEMORY/ENTER** key or the **ENTER** key to return to the display mode selected in step 7.

# Normal playback

## Preparing for playback

Some preparatory steps are needed before starting playback.

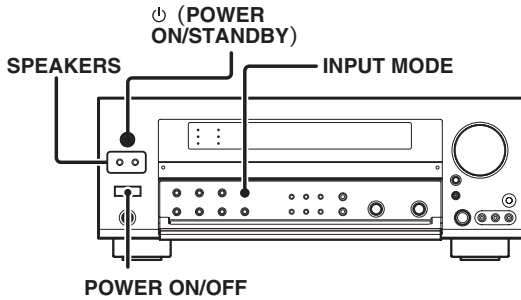

### Turning on the receiver

- 1 Turn on the power to the related components.
- 2 Turn on the power to this receiver by pressing the **POWER ON/OFF** and **⏻ (POWER ON/STANDBY)** key.

### Selecting the input mode

If you have selected a component connected to the **CD/DVD**, **VIDEO 2**, **VIDEO 3** or **DVD/6CH** jacks, make sure that the input mode setting is correct for the type of audio signal to be used. 

### Selecting the speaker system

Press the **SPEAKERS** key to select the speaker system to be used.

- A ON** : Sound from the speakers connected to the **SPEAKERS A** terminals.
- B ON** : Sound from the speakers connected to the **SPEAKERS B** terminals.
- A ON, B ON** : Sound from both the speakers connected to the **SPEAKERS A** and **B** terminals.
- OFF** : No sound from the speakers.

The indicator for the speakers you want to use should be lit.

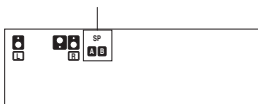

- Selecting "6CH INPUT" by pressing the **INPUT MODE** key, whereby "DVD/6CH" is the input source will cause **SPEAKERS A** to be selected automatically.
- When the **SPEAKERS B** is turned ON, the Listen mode will be switched to Stereo.
- Turn on **SPEAKERS A** if using PRE OUT terminals including Subwoofer to output sound.

## Listening to a source component

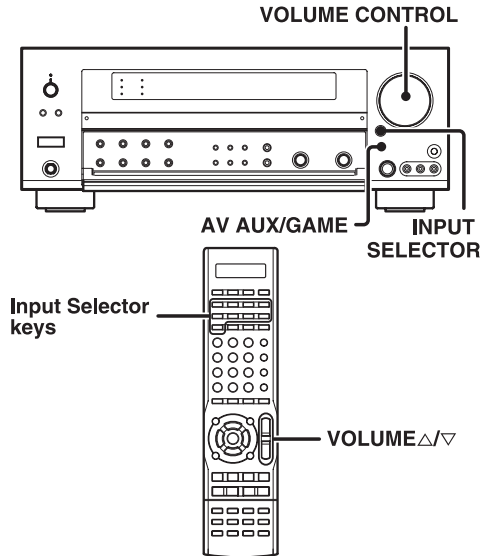

- 1 Use the **INPUT SELECTOR** and **AV AUX/GAME** keys or **Input Selector** keys to select the source you want to listen to.

Selecting a source using each key.

- 1 TUNER
- 2 CD/DVD
- 3 MD/TAPE
- 4 VIDEO 1
- 5 VIDEO 2
- 6 VIDEO 3
- 7 DVD/6CH
- 8 PHONO
- 9 AV AUX [GAME] (or AV AUX)

- 2 Start playback from the selected source.

- 3 Use the **VOLUME CONTROL** knob or **VOLUME Δ/▽** keys to adjust the volume.

### Set up the AV AUX jacks on the front panel

Perform the setup for convenience of playing a video game using the receiver.

- 1 Use the **AV AUX/GAME** key to select "AV AUX [GAME]" (or "AV AUX").
- 2 Press and hold the **AV AUX/GAME** key for more than 2 seconds for the following selections:
  - 1 **AV AUX [GAME]** : When the connected game player is turned ON, the input selector is switched automatically to "AV AUX [GAME]". In addition, the ACTIVE EQ function is switched to "ACTIVE EQ GAME", and the Listen mode is switched to the appropriate mode for games.
  - 2 **AV AUX** : The game mode is switched off.

- The game mode is not activated if no video signal is input to the **VIDEO** or **S-VIDEO** jack in the **AV AUX** jack section.

## Input level adjustment (analog sources only)

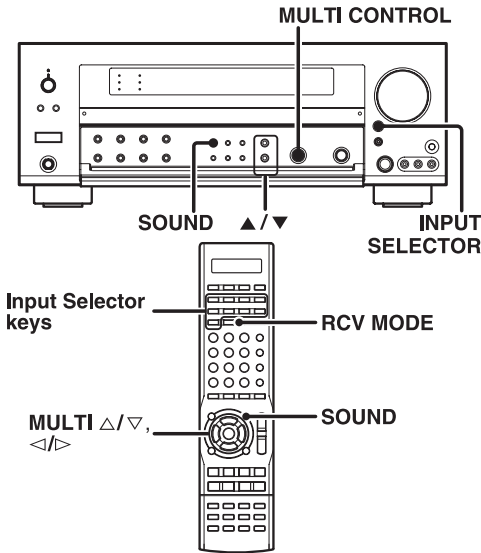

### Input level adjustment (analog sources only)

If the input level of an analog source signal is too high, the **CLIP** indicator will blink. Adjust the input level.

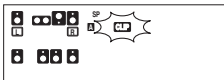

- ❶ Use the **INPUT SELECTOR** key or **Input Selector** keys to select the source of which the input level you want to adjust.
  - You can store a separate input level for each input source.
- ❷ For the remote control unit, press the **RCV MODE** key to switch to receiver mode.
- ❸ Press the **SOUND** key and  **$\Delta/\nabla$**  keys or **MULTI  $\Delta/\nabla$**  keys repeatedly until the "INPUT" indication appears.
- ❹ Use the **MULTI CONTROL** knob or **MULTI  $\Delta/\nabla$**  keys to adjust the input level.

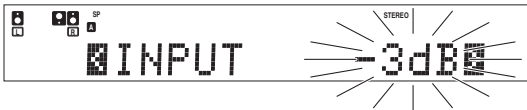

- The adjustment mode is displayed for approximately 20 seconds.
- The input level can be adjusted to any one of three settings: 0dB, -3dB, and -6dB. (The initial setting is 0dB.)

- ❺ Press the **SOUND  $\Delta/\nabla$**  key to accept the setting.

## Adjusting the sound

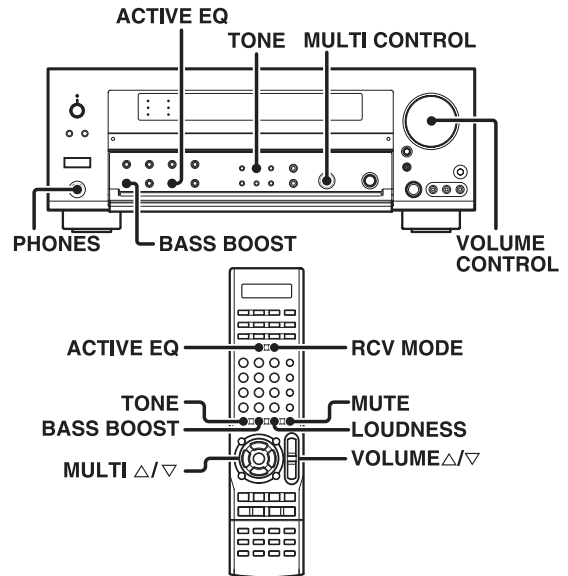

### ACTIVE EQ mode

After completing "Setting up the speakers automatically (AUTO SETUP)", the most suitable equalizer curve for the frequency characteristics of your speakers and the room will be set for each ACTIVE EQ mode.

- ❶ For the remote control unit, press the **RCV MODE** key to switch to receiver mode.
- ❷ Press the **ACTIVE EQ** key for the following selections;
  - ❶ **ACTIVE EQ OFF** : The ACTIVE EQ function is turned OFF.
  - ❷ **ACTIVE EQ FLAT\*** : Frequency response from speakers are flat.
  - ❸ **ACTIVE EQ MUSIC** : Effective when listening to music.
  - ❹ **ACTIVE EQ CINEMA** : Effective when watching movie.
  - ❺ **ACTIVE EQ GAME** : Effective when playing video game.  
\*It can be selected after **AUTO SETUP** is carried out.



- If **THX** key is pressed, ACTIVE EQ mode is changed to "ACTIVE EQ FLAT" automatically. After that you can change the ACTIVE EQ mode by pressing the **ACTIVE EQ** key.
- ACTIVE EQ function will not be available when in REC mode.

### Adjusting the TONE

You can adjust the sound quality when the receiver is in the PCM stereo and analog stereo mode, and both THX and Virtual mode are off.

- 1 For the remote control unit, press the RCV MODE key to switch to receiver mode.
- 2 Press the TONE key to select the TONE mode.
- 3 Use the MULTI CONTROL knob or MULTI  $\Delta/\nabla$  keys to select TONE ON/OFF.

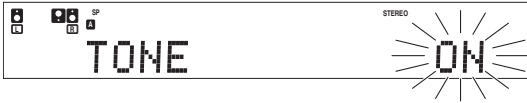

- 4 When in TONE ON selection, press the TONE key for the following displays.

**BASS** : Select this to adjust the low frequency range.  
**TREBLE** : Select this to adjust the high frequency range.

- 5 Use the MULTI CONTROL knob or MULTI  $\Delta/\nabla$  keys to adjust the sound quality.



- The bass and treble levels are adjustable from -10 to +10 in 2 step increments.
- The adjustment item is displayed for approximately 20 seconds.
- This function is available only for speakers connected to FRONT A terminals.

### Setting the LOUDNESS (remote control unit only)

You can adjust the Loudness function which controls the low volume settings to maintain the music's richness. This setting can be made when the receiver is in the PCM stereo and analog stereo mode, and both THX and Virtual mode are off.

Press the LOUDNESS key to turn the LOUDNESS setting ON.

- This function is available only for speakers connected to FRONT A terminals.

#### To cancel

Press the LOUDNESS key again so that the "LOUDNESS" indicator goes off.

### One-touch low frequency emphasis (BASS BOOST)

This setting can be made when the receiver is in the PCM stereo and analog stereo mode, and both THX and Virtual mode are off.

Press the BASS BOOST key.

- Press the key once to select the maximum (+10) low frequency emphasis setting.
- This key does not function when the receiver is in the sound quality or ambience effects adjustment mode.
- This function is available only for speakers connected to FRONT A terminals.

#### Switching back to the previous setting

Press the BASS BOOST key again.

### Muting the sound

The MUTE key lets you mute the sound of the speakers.

Press the MUTE key.

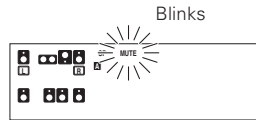

#### To cancel

Press the MUTE key again so that the "MUTE" indicator goes off.

- MUTE ON can also be deactivated by turning the VOLUME CONTROL knob or pressing VOLUME  $\Delta/\nabla$  keys.

### Listening with headphones

- 1 Connect headphones to the PHONES jack.

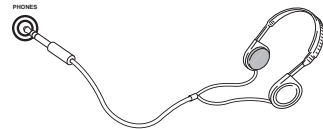

- The sounds from all speakers are cut off.

- 2 Use the VOLUME CONTROL knob or VOLUME  $\Delta/\nabla$  keys to adjust the volume.

# Recording

## Recording audio (analog sources)

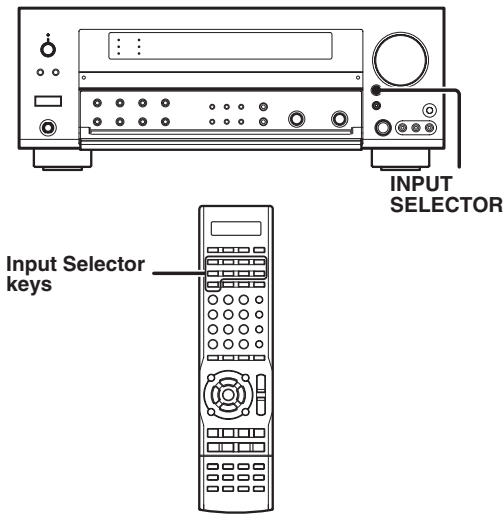

### Recording a music source

- 1 Use the **INPUT SELECTOR** key or the Input Selector keys to select the source (other than "MD/TAPE") you want to record.
- 2 Set the MD or TAPE recorder to record.
- 3 Start playback, then start recording.

## Recording audio (digital sources)

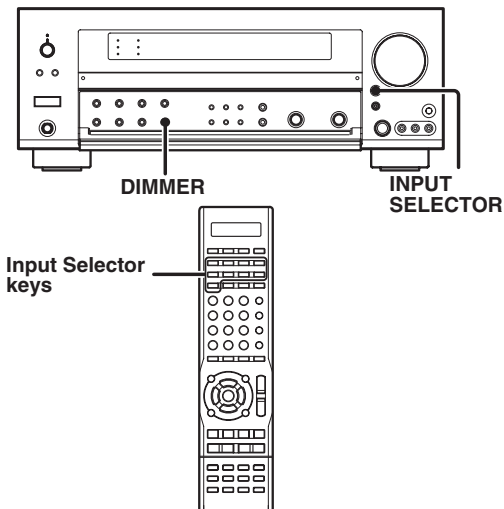

### Recording music in REC MODE AUTO or MANUAL

- 1 Use the **INPUT SELECTOR** key or the Input Selector keys to select the source (CD/DVD, DVD/6CH, VIDEO 2, VIDEO 3) you want to record.
- 2 Set the MD or TAPE recorder to record.
- 3 Press and hold the **DIMMER** key for more than 2 seconds for the following selections:
  - 1 **REC MODE off**
  - 2 **REC MODE AUTO** : The digital input signals (DTS, Dolby Digital, or PCM) are identified automatically and converted into stereo signals that are ready for recording.
  - 3 **REC MODE MANUAL** : The digital input signals (DTS, Dolby Digital, or PCM) are identified and converted into stereo signals that are ready for recording. Once the digital signal is changed to other signal, no signal is output.

For REC MODE AUTO :

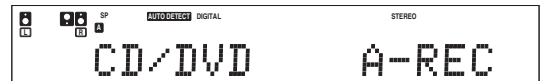

For REC MODE MANUAL :



- 4 Start playback, then start recording.
  - If the audio reproduction stops in the middle due to change in the input signals, etc., press the **DIMMER** key.

## Recording video

- 1 Use the **INPUT SELECTOR** key or the Input selector keys to select the video source (other than "VIDEO 1") you want to record.
- 2 Set the video recorder connected to **VIDEO 1** to record.
  - Select the REC MODE to record a digital input source.
- 3 Start playback, then start recording.
  - Recording may not be normal for some video software. This is due to the copy guard condition.

# Listening to radio broadcasts

This model can store up to 40 stations in the memory and recall them by one-touch operation. Radio stations can be classified into RDS (Radio Data System) stations and other stations. To listen to or store RDS stations in the preset memory see "Using RDS (Radio Data System)".

## Tuning (non-RDS) radio stations

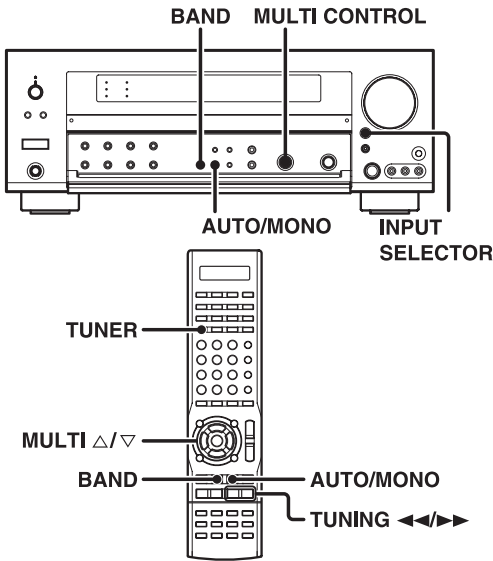

**1 Use the INPUT SELECTOR key or the TUNER key to select the tuner.**

**2 Use the BAND key to select the desired broadcast band.**

Each press switches the band.



**3 Use the AUTO/MONO key to select the desired tuning method.**

Each press switches the tuning method to either auto or manual tuning.

"AUTO" indicator lights up in the display.



- Normally, set to "AUTO" (auto tuning). If the radio waves are weak and there is a lot of interference, switch to manual tuning. (With manual tuning, stereo broadcasts will be received in monaural.)

**4 Use the MULTI CONTROL knob or MULTI Δ/∇ keys, or TUNING <=> keys to select the station.**

"STEREO" lights when a broadcast is being received in stereo.

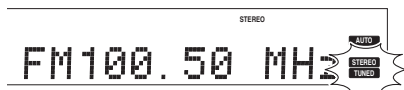

"TUNED" is displayed when a station is received.

**Auto tuning** : The next station is tuned automatically.  
**Manual tuning** : Turn the knob or use the **MULTI Δ/∇** keys to select the desired station.

## Using RDS (Radio Data System)

RDS is a system that transmits useful information (in the form of digital data) for FM broadcasts along with the broadcast signal. Tuners and receivers designed for RDS reception can extract the information from the broadcast signal for use with various functions, such as automatic display of the station name.

### RDS functions:

**PTY (Program TYPe Identification) Search** - [33]  
 Automatically tunes to a station that is currently broadcasting the specified program type (genre).

**PS (Program Service Name) Display**  
 Automatically displays the station name transmitted by the RDS station.

**RDS AUTO MEMORY function** - [32]  
 Automatically selects and stores up to 40 RDS stations in the preset memory. If fewer than 40 RDS stations have been stored in the preset memory, regular FM stations will be stored in the remaining places.

**Radio Text function**  
 Displays the radio text data transmitted by some RDS stations when you press the **RDS DISP** (display) key. There is "NO RT" if no text data is transmitted. The "RDS" indicator lights up when an RDS broadcast (signal) is received.



Note

Some functions and function names may differ for certain countries and areas.

Before using a function utilizing the RDS, be sure to perform the RDS Auto Memory operation by referring to the description in "Presetting RDS stations (RDS AUTO MEMORY)". - [32]

## Presetting radio stations manually

The RDS auto memory function assigns preset numbers to RDS stations starting from preset number "1". Therefore, be sure to execute the RDS auto memory function before using the following operations to manually store AM stations and other FM stations, and RDS stations. See "Presetting RDS stations (RDS AUTO MEMORY)". - 32

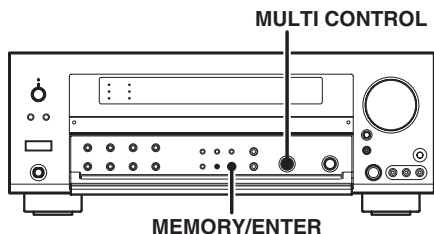

- 1** Tune to the station you want to store.
- 2** Press the **MEMORY/ENTER** key while receiving the station.

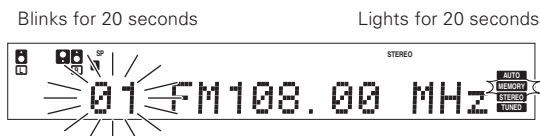

Proceed to step **3** within 20 seconds.  
(If more than 20 seconds elapse, press the **MEMORY/ENTER** key again).

- 3** Use the **MULTI CONTROL** knob to select one of the station presets (1 – 40).
- 4** Press the **MEMORY/ENTER** key again to confirm the setting.
  - Repeat steps **1**, **2**, **3**, and **4** to store as many stations as necessary.
  - If you store a station at a previously used preset, the old station will be replaced by the new one.

## Receiving preset stations

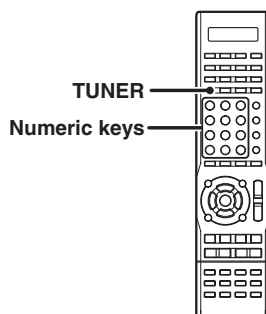

- 1** Press the **TUNER** key to select tuner as the source.
- 2** Enter the number of the preset station you want to receive (up to "40").

Press the **Numeric** keys in the following order:

For "15", press **+10**, **5**  
For "20", press **+10**, **+10**, **0**

- If you make a mistake entering a two digit number, press the **+10** key repeatedly to return to the original display and start again.



## Receiving preset stations in order (P.CALL)

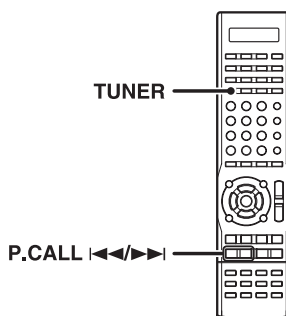

- 1** Press the **TUNER** key to select the tuner as the source.
- 2** Use the **P.CALL** **◀◀**/**▶▶** keys to select the desired station.

- Each time you press the key, another preset station is received in order.

Pressing the **P.CALL** **▶▶** does the following:

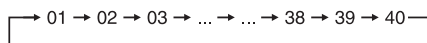

Pressing the **P.CALL** **◀◀** does the following:

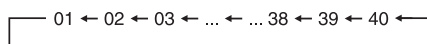

Holding down the **P.CALL** **◀◀** or **▶▶** key, lets you skip through the presets, receiving each preset station at 0.5 second intervals.

## Using the RDS DISP (Display) key

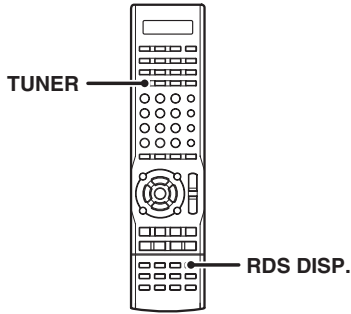

Pressing the RDS DISP. key changes the contents of the display.

Each press switches the display mode as follows :

- ① PS (Program Service name) display
- ② RT (Radio Text) display
- ③ Frequency display

① **PS (Program Service name) display :**

The station name is displayed automatically when an RDS broadcast is received.  
If no PS data was sent, "NO PS" is displayed.



② **RT (Radio Text) display :**

Text data accompanying the RDS broadcast scrolls across the display.  
"NO RT" is displayed if the current RDS station does not provide RT data.



③ **Frequency display :**

Displays the frequency of the current station.



## Presetting RDS stations (RDS AUTO MEMORY)

This function automatically stores up to 40 RDS stations in the preset memory. In order to use the PTY function, the RDS stations must be stored in the preset memory using the RDS AUTO MEMORY function.

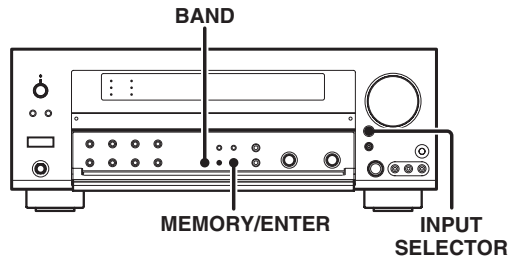

① Press the INPUT SELECTOR key to select the tuner mode.

② Use the BAND key to set the broadcast band to "FM".

③ Press the MEMORY/ENTER key continuously for more than 2 seconds will start AUTO MEMORY.

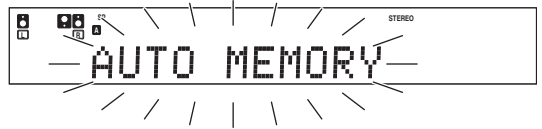

- After a few minutes, up to 40 RDS stations are preset in order from channel "01".
- Stations already stored in the preset memory may be replaced by RDS stations. (i.e., If the RDS AUTO MEMORY function detects 15 RDS stations, the stations currently preset at numbers 01~15 will be replaced by the RDS stations.)

## Tuning by Program Type (PTY search)

This function lets you set the tuner to automatically search for stations which are currently broadcasting the type of program (genre) you want to listen to.

Under certain receiving conditions, it may take more than 1 minute to complete the search.

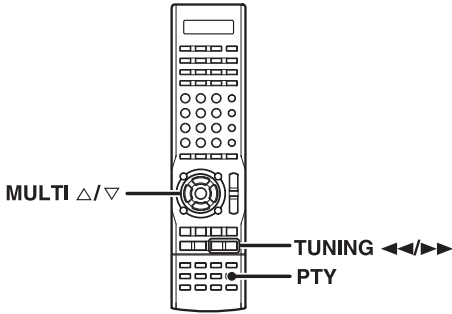

### Preparations

- Execute the RDS auto memory procedure.
- Set the broadcast band to FM.

### 1 Press the PTY key to activate the PTY search mode.



When an RDS broadcast is received, the program type is shown on the display. If no PTY data is available, or if the station is not an RDS station, "NONE" is displayed.

### 2 While the "PTY" indicator is lit, use the MULTI Δ/∇ keys or TUNING ◀/▶ keys select the program type of your choice.

#### Program type table

Program Type Name	Display	Program Type Name	Display
Pop Music	POP M	Weather	WEATHER
Rock Music	ROCK M	Finance	FINANCE
Easy Music	EASY M	Children's Program	CHILDREN
Light Classical Music	LIGHT M	Social Affairs	SOCIAL
Serious Classical Music	CLASSICS	Religion	RELIGION
Other Music	OTHER M	Phone In	PHONE IN
News	NEWS	Travel	TRAVEL
Current Affairs	AFFAIRS	Leisure	LEISURE
Information	INFO	Jazz Music	JAZZ
Sport	SPORT	Country Music	COUNTRY
Education	EDUCATE	National Music	NATION M
Drama	DRAMA	Oldies Music	OLDIES
Culture	CULTURE	Folk Music	FOLK M
Science	SCIENCE	Documentary	DOCUMENT
Varied Speech	VARIED		

### 3 Press the PTY key to start searching.

EXAMPLE : Searching for a Pop Music broadcast.

Display while searching.

Blinks

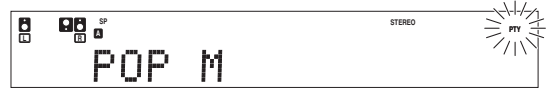

Program type name display

Display when a station is received.

Goes out



Station name display

- No sound is heard while "PTY" is blinking.
- If the desired program type cannot be found, "NO PROGRAM" is displayed, then after several seconds the display returns to the original display.

### To select another program type.

Repeat steps 1, 2 and 3.

# Ambience effects

This receiver is equipped with listening modes that allow you to enjoy an enhanced sonic ambience with a variety of video sources.

In order to obtain the optimum effect from the surround modes, make sure to input the proper speaker settings beforehand.

## Surround modes

The below image is for 5.1 channel surround sound system which are;

- Dolby Digital
- DTS 96/24
- Dolby Pro Logic II
- DVD 6-channel
- DTS

The below image is for 6.1 channel surround sound system which are;

- Dolby Digital EX
- Neo:6
- DTS-ES
- DSP mode
- THX Surround EX

The below image is for 7.1 channel surround sound system which is;

- THX Select2 Cinema
- Dolby Pro Logic IIx

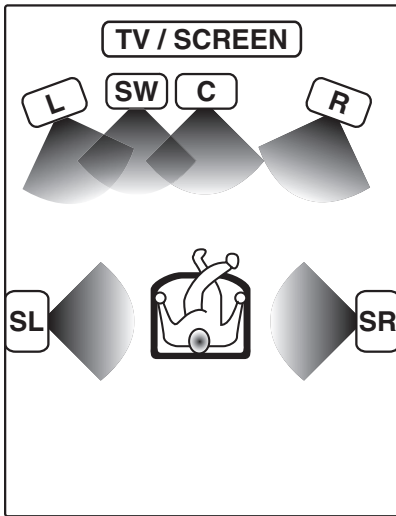

No Surround Back Speaker

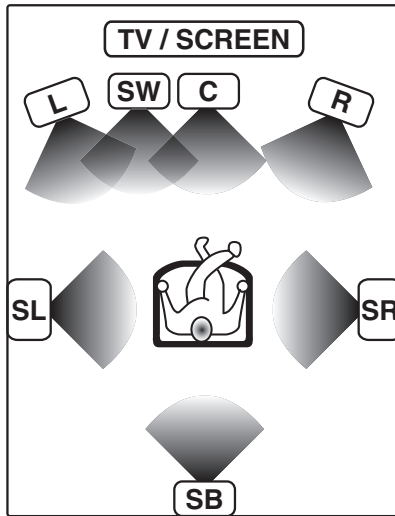

With Surround Back Speaker

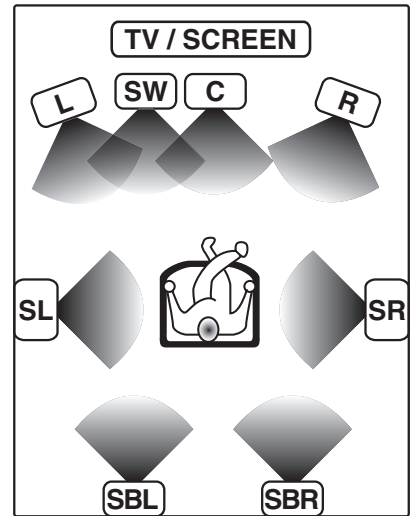

With Surround Back Left and Right Speakers

The below image is for Dolby Virtual Speaker mode.

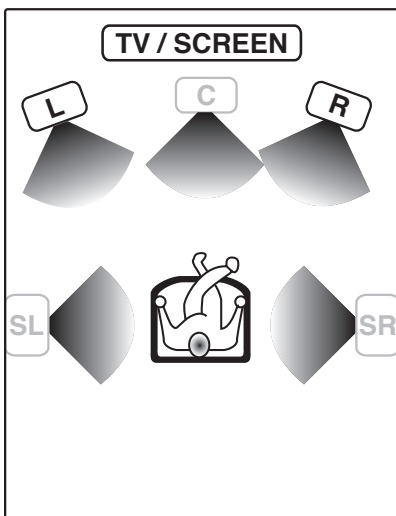

With Front Left and Right Speakers

- L** Front Left Speaker
- SW** Subwoofer
- C** Center Speaker
- R** Front Right Speaker
- SL** Surround Left Speaker
- SR** Surround Right Speaker
- SB** Surround Back Speaker
- SBL** Surround Back Left Speaker
- SBR** Surround Back Right Speaker

Manufactured under license from Dolby Laboratories. "Dolby", "Pro Logic", "Surround EX" and the double-D symbol are trademarks of Dolby Laboratories.

"DTS", "DTS-ES", "Neo:6" and "DTS 96/24" are trademarks of Digital Theater Systems, Inc.



THX, Select2 and THX logo are trademarks of THX Ltd. THX may be registered in some jurisdictions. All rights reserved. Surround EX is a trademark of Dolby Laboratories. Used with permission.

### **Dolby Digital**

The Dolby Digital surround format lets you enjoy up to 5.1 channels of digital surround sound from Dolby Digital program sources (such as Laserdisc or DVD software marked ). Compared with previous Dolby surround, Dolby Digital provides even better sound quality, greater spatial accuracy, and improved dynamic range.

### **Dolby Digital EX**

Dolby Digital EX is an extension of Dolby Digital technology, Dolby Digital EX creates six full-bandwidth output channels from 6.1-channel sources. This is done using a matrix decoder that derives three surround channels from the two in the original recording. This is achieved by using three different surround signals, surround left, surround right, and surround back, each driving its own array of speakers. Think of it as adding a center channel for the rear speakers, which give more diffuse and natural surround effect, even if you wanted the ability to completely encircle the audience with sound, positioning sound effects exactly where they would be heard in real life. For best results, Dolby Digital EX should be used with movie soundtracks recorded with Dolby Digital Surround EX which contain a digital flag that will automatically activate this feature. However, for titles released prior to late 2001, this feature has to be activated manually.

Although Dolby Digital soundtracks incorporate a separate low frequency channel, connecting a subwoofer will also improve deep bass performance in the other surround modes. The indication "LFE" appears in the display when a signal is being input for this channel.

### **Dolby Pro Logic IIx and Dolby Pro Logic II**

Dolby Pro Logic II was designed specifically to provide a new sense of spatiality, directionality and articulation of sounds from Dolby Surround encoded sources (such as video and Laserdisc software marked ). This is achieved with an intelligent, built-in feedback logic design, a matrix surround decoding and the decoding of stereo, full bandwidth surround outputs. Dolby Pro Logic IIx enhanced Dolby Pro Logic II's features. It creates 6.1 channel and 7.1 channel surround sound from stereo or 5.1 channel signals. This feature provides you an astonishing ambience effect which makes you feel you are surrounded by natural sound. Especially 7.1 channel surround sound can produce real back sound from Surround Back speakers.

The Pro Logic IIx modes programmed into this model are "Movie", "Music" and "Game". The Pro Logic II modes programmed into this model are "Movie", "Music", "Game" and "Pro Logic". The "Movie" mode has preset characteristics to produce a calibrated, high-level surround sound playback while the "Music" mode has user-adjustable characteristics to offer the three optional controls, like "Dimension", "Center Width" and "Panorama" modes to allow optimization of the soundfields as desired. The "Dimension" control allows the user to gradually adjust the soundfield either towards the front or towards the rear; the "Center Width" control allows various adjustment of the left-center-right speakers' balance; the "Panorama" mode extends the front stereo image to include the surround speakers for an exciting "wrap-around" effect with side wall imaging.

The "Game" mode provides surrounded and exciting sound when you enjoy game or TV. Especially in Pro Logic IIx "Game" mode, base sound not only from Front and Center but also from Surround channel is added to Subwoofer. This provides ever more dynamic surround effects.

### **DSP mode**

The DSP mode lets you add the atmosphere of a live concert or hall to almost any type of program source. The way a sound is heard in an actual environment depends on a variety of different factors. One of the most important is reverberation (the act of decaying elements of sound echoing in various places).

The DSP modes produce the feeling of presence by using the DSP to create reverberation, without spoiling the sound quality of the original signal. These modes are particularly effective when used with stereo program sources, like CD, television, and FM radio. You might enjoy trying the Arena, Jazz Club, Theater, Stadium or Disco mode the next time you watch a concert or sporting event!

### **Dolby Virtual Speaker**

The Dolby Virtual Speaker features a virtual surround sound field. This implements an effect as if there are multiple speakers in the listening room.

### **Dolby Headphone**

When headphones are used in music listening, the audio of the left (or right) channel reaches only the left (or right) ear so the listener cannot feel the presence of acoustic images on the front.

The Dolby Headphone simulates a virtual room and include its acoustic characteristics in the left and right headphone signals. As a result, the listener can hear the same components as in speaker listening through the left and right ears and therefore feel as if the sound source is located on the front of the listener.

Because of the same processing in "Pro Logic II Movie mode with Dolby Headphone" and "Pro Logic II Game mode with Dolby Headphone", their respective effectiveness is the same.

### **DTS**

The DTS multi-channel audio format is available on CD, LD and DVD software. DTS is a strictly digital format and cannot be decoded inside most CD, LD or DVD players. For this reason, if you attempt to listen to DTS encoded software through the analog output of your new CD, LD or DVD player, you will experience digital noise in most cases. This noise can be quite loud if the analog output is connected directly to a high power amplification system. Proper measures for playing the digital output as described below should be taken to avoid this situation. To enjoy DTS Digital Surround playback, an external 5.1 channel DTS Digital Surround decoder system or an amplifier with a built-in DTS Digital Surround decoder must be connected to the digital output (S/P DIF, AES/EBU or TosLink) of a CD, LD or DVD player. All models are incorporated with the DTS decoder.

### **DTS-ES**

DTS-ES (Digital Theater System-Extended Surround) presents 6.1 channels surround system with additional Surround Back channel which evolved from the conventional 5.1 channels surround system. DTS-ES format that was recorded in DVD, CD or LD comprises of two modes. DTS-ES Discrete 6.1 produces the discrete surround back which is completely independent and DTS-ES Matrix 6.1 produces the surround back which synthesised within the left and right surround channels using matrix technology. DTS-ES has perfect compatibility with the conventional 5.1 channels surround system. 6.1 channels surround with an additional surround back presents a more natural presence and surround effects by increasing the impression of the sound image from back. Programs which are recorded using DTS-ES technology consist of information flags which will be able to control the Discrete and Matrix mode. Thus, it can automatically select the best matched mode.

### **Neo:6**

Neo:6 is a new technology which was developed by DTS. It can produce high grade 6 channels surround with an astonishing fidelity from 2 channels content. Neo:6 has 2 modes, "Cinema" mode is for movie playback and "Music" mode is for music playback.

### **DTS 96/24**

DTS 96/24 made it possible to achieve a wide frequency range of over 40 kHz by increasing the sampling frequency to 96 or 88.2 kHz. Moreover, DTS 96/24's ability of 24 bit resolution offers the same frequency band and dynamic range as 96 kHz/24 bit PCM. DTS 96/24 is, as with conventional DTS Surround, compatible with multi-channels. Therefore, sources recorded using DTS 96/24 technologies can be played in high sampling frequency, multi-channel audio with ordinary DVDs and CDs.

DTS has a ".1" or "LFE" channel.

The indication "LFE" appears in the display when a signal is being input for this channel.

### **Note**

**LFE** = Low Frequency Effects. This channel delivers separate non-directional bass signals to the subwoofer for more dynamic deep bass sound effects.

### **THX**

THX is an exclusive set of standards and technologies established by the world-renowned film production company, Lucasfilm Ltd. THX grew from George Lucas' personal desire to make your experience of the film soundtrack, in both movie theatres and in your home theatre, as faithful as possible to what the director intended.

Movie soundtracks are mixed in special movie theatres called dubbing stages and are designed to be played back in movie theatres with similar equipment and conditions. This same soundtrack is then transferred directly onto Laserdisc, VHS tape, DVD, etc., and is not changed for playback in a small home theatre environment.

THX engineers developed patented technologies to accurately translate the sound from the movie theatre environment into the home, correcting the tonal and spatial errors that occur. On this product, when the THX indicator is on, THX features are automatically added in Cinema modes (e.g. THX Cinema, THX Surround EX):

#### **Re-equalization (Re-EQ)**

The tonal balance of a film soundtrack will be excessively bright and harsh when played back over audio equipment in the home because film soundtracks were designed to be played back in large movie theatres using very different professional equipment. Re-Equalization restores the correct tonal balance for watching a movie soundtrack in a small home environment.

#### **Timbre Matching**

The human ear changes our perception of a sound depending on the direction from which the sound is coming. In a movie theatre, there is an array of surround speakers so that the surround information is all around you. In a home theatre, you use only two speakers located to the side of your head. The Timbre Matching feature filters the information going to the surround speakers so that they more closely match the tonal characteristics of the sound coming from the front speakers. This ensures seamless panning between the front and surround speakers.

#### **Adaptive Decorrelation**

In a movie theatre, a large number of surround speakers help create an enveloping surround sound experience, but in a home theatre there are usually only two speakers. This can make the surround speakers sound like headphones that lack spaciousness and envelopment. The surround sounds will also collapse into the closest speaker as you move away from the middle seating position. Adaptive Decorrelation slightly changes one surround channel's time and phase relationship with respect to the other surround channel. This expands the listening position and creates - with only two speakers - the same spacious surround experience as in a movie theatre.

#### **THX Select 2**

Before any home theatre component can be THX Select 2 certified, it must incorporate all the features above and also pass a rigorous series of quality and performance tests. Only then can a product feature the THX Select 2 logo, which is your guarantee that the Home Theatre products you purchase will give you superb performance for many years to come. THX Select 2 requirements cover every aspect of the product including pre-amplifier performance and operation, and hundreds of other parameters in both the digital and analog domain.

#### **DVD 6-channel mode**

Using a DVD player or the like equipped with six (5.1) output channels and the receiver, you can enjoy multi-channel encoded DVD source material in all its splendor. Since the source signals are digital and each channel is input independently, the resulting sound quality, sense of spaciousness, and dynamic range are superb.

### **ASA (Advanced Speaker Array)**

ASA is a proprietary THX technology which processes the sound fed to 2 side and 2 back surround speakers to provide the optimal surround sound experience. When you set up your home theater system using all eight speaker outputs (Left, Center, Right, Surround Right, Surround Back Right, Surround Back Left, Surround Left and Subwoofer) placing the two Surround Back speakers close together facing the front of the room as shown in the diagram will provide the largest sweet spot. If for practical reasons you have to place the Surround Back speakers apart, you will need to go THX Audio Set-up screen and choose the setting that most closely corresponds to the speaker spacing, which will re-optimize the surround sound-field. ASA is used in three new modes; THX Select 2 Cinema, THX MusicMode and THX Games Mode.

#### **THX Select 2 Cinema mode.**

THX Select 2 Cinema mode plays 5.1 movies using all 8 speakers giving you the best possible movie watching experience. In this mode, ASA processing blends the side surround speakers and back surround speakers providing the optimal mix of ambient and directional surround sounds.

DTS-ES (Matrix and 6.1 Discrete) and Dolby Digital Surround EX encoded soundtracks will be automatically detected in Select 2 Cinema mode if the appropriate flag has been encoded.

Some Dolby Digital Surround EX soundtracks are missing the digital flag that allows automatic switching. If you know that the movie that you are watching is encoded in Surround EX, you can manually select the THX Surround EX playback mode, otherwise THX Select 2 Cinema mode will apply ASA processing to provide optimum replay.

#### **THX MusicMode.**

For the replay of multi-channel music the THX MusicMode should be selected. In this mode THX ASA processing is applied to the surround channels of all 5.1 encoded music sources such as DTS, Dolby Digital and DVD-Audio to provide a wide stable rear soundstage.

#### **THX Games Mode.**

For the replay of stereo and multi-channel game audio the THX Games Mode should be selected. In this mode THX ASA processing is applied to the surround channels of all 5.1 and 2.0 encoded game sources such as analog, PCM, DTS and Dolby Digital. This accurately places all game audio surround information, providing a full 360 degree playback environment. THX Games Mode is unique as it gives you a smooth transition of audio in all points of the surround field.

### **THX Surround EX**

THX Surround EX-Dolby Digital Surround EX is a joint development of Dolby Laboratories and the THX division of Lucasfilm Ltd.

In a movie theatre, film soundtracks that have been encoded with Dolby Digital Surround EX technology are able to reproduce an extra channel which has been added during the mixing of the program. This channel, called Surround Back, places sounds behind the listener in addition to the currently available front left, front center, front right, surround right, surround left and subwoofer channels. This additional channel provides the opportunity for more detailed imaging behind the listener and brings more depth, spacious ambience and sound localization than ever before.



Movies that were created using the Dolby Digital Surround EX technology, when released into the home consumer market may exhibit a Dolby Digital Surround EX logo on the packaging. A list of movies created using this technology can be found on the Dolby web site at <http://www.dolby.com>.

Only receiver and controller product bearing the THX Surround EX logo, when in the THX Surround EX mode, faithfully reproduce this new technology in the home.

This product may also engage the "THX Surround EX" mode during the playback of 5.1 channel material that is not Dolby Digital Surround EX encoded. In such case the information delivered to the Surround Back channel will be program dependent and may or may not be very pleasing depending on the particular soundtrack and the taste of the individual listener.

## Surround play

DTS can be used when playing CD, DVD or LD software carrying the DTS mark.

Dolby Digital can be used when playing DVD or LD software bearing the  mark and Dolby Digital format digital broadcasts (etc.). Dolby Pro Logic can be used when playing video, DVD, or LD software bearing the  mark.

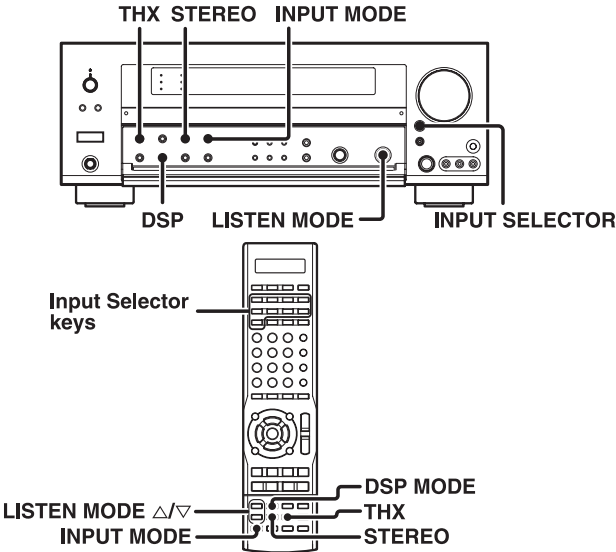

### Preparations

- Turn ON related components.
- Complete "Preparing for surround sound". - [19]
- Use the **INPUT SELECTOR** key or **Input Selector** keys to select the component you wish to play back with surround sound.
- Use the **INPUT MODE** key to select the input mode (analog or digital) for the source you wish to play back. - [8]

### Note

- Noise may be produced when a DTS source is played by selecting the analog input.

### 1 Start playing the video software.

### 2 Selecting the THX mode.

This mode creates a home theater environment which is able to reproduce a cinema surround sound system featuring improved special representation and acoustic imaging of surround channels by translating THX technology.

Press the THX key to switch the following setting :

- 1 **THX OFF** : THX mode is turned OFF.
- 2 **THX Select2 Cin** : Effective when watching movie.
- 3 **THX MusicMode** : Effective when listening to music.
- 4 **THX Games** : Effective when playing video game.
- 5 **THX Cinema** : Effective when watching movie.

- THX functions when the display segment is turned ON.
- The THX setting differs depending on the input selector.

### 3 Use the LISTEN MODE knob or LISTEN MODE Δ/▽ keys to select the listening mode.

The listening mode settings are stored separately for each input. If the input mode is set to full auto ("AUTO DETECT" lights), the receiver selects the optimal listening mode automatically based on the type of input signal and the speaker settings.

Each turn of the LISTEN MODE knob or press of the LISTEN MODE Δ/▽ keys switches the setting as listed below.









The listening mode settings are different depending on the type of input signal.

### Dolby Digital Surround EX compliant disc :

Dolby Digital Surround EX compliant disc contains identification signals. When you choose **FULL AUTO** during "Input mode settings" (- [8]), this amplifier detects the identification signals and selects an optimum LISTEN mode automatically.

Sometimes we find some discs which are Dolby Digital Surround EX compliant discs but do not contain the identification signals. In this case, select one of the LISTEN modes which are for 6.1 or 7.1 channel surround mode.

### When the Dolby Digital or Dolby Digital EX signal is input :

- 1  **D+THX Cinema** : Dolby Digital+THX Cinema\*1
- 2  **D+THX Surround EX** : Dolby Digital+THX Surround EX\*1
- 3  **D+PLIIx Movie+THX Cinema** : Dolby Digital+Pro Logic IIx Movie mode+THX Cinema\*1
- 4 **PLIIx Movie+THX Cinema** : Pro Logic IIx Movie mode +THX Cinema\*1
- 5 **Pro Logic+THX Cinema** : Pro Logic+THX Cinema\*1
- 6 **Stereo+THX Cinema** : Stereo+THX Cinema\*1
- 7  **D+THX Games** : Dolby Digital+THX Games\*2
- 8 **2.0 THX Games** : Dolby Digital(2 channel signals) +2.0 THX Games\*2
- 9  **D+THX MusicMode** : Dolby Digital+THX Music Mode\*3
- 10  **D+THX Select2 Cinema** : Dolby Digital+THX Select2 Cinema\*4
- 11 **Dolby Digital** : Dolby Digital\*5
- 12 **Dolby D EX** : Dolby Digital EX\*5
- 13  **D+PLIIx Movie** : Dolby Digital+Pro Logic IIx Movie mode\*5
- 14  **D+PLIIx Music** : Dolby Digital+Pro Logic IIx Music mode\*5
- 15 **PLIIx Movie** : Dolby Pro Logic IIx Movie mode\*5
- 16 **PLIIx Music** : Dolby Pro Logic IIx Music mode\*5
- 17 **PLIIx Game** : Dolby Pro Logic IIx Game mode\*5
- 18 **PLII Movie** : Dolby Pro Logic II Movie mode\*5
- 19 **PLII Music** : Dolby Pro Logic II Music mode\*5
- 20 **PLII Game** : Dolby Pro Logic II Game mode\*5
- 21 **Pro Logic** : Dolby Pro Logic\*5
- 22 **Stereo** : stereo\*5

When you select Dolby Digital "Dolby Digital" will be displayed.



### When the DTS or DTS-ES (matrix or discrete) signal is input :

- 1 **DTS+Neo:6+THX Cinema** : DTS+Neo:6 Cinema+THX Cinema\*1
- 2 **DTS-ES Matrix 6.1+THX Cinema** : DTS-ES Matrix 6.1+THX Cinema\*1
- 3 **DTS-ES Discrete 6.1+THX Cinema** : DTS-ES Discrete 6.1+THX Cinema\*1
- 4 **DTS+THX Cinema** : DTS+THX Cinema\*1
- 5 **DTS 96/24+THX Cinema** : DTS 96/24+THX Cinema\*1
- 6 **Stereo+THX Cinema** : Stereo+THX Cinema\*1
- 7 **Neo:6 Cinema+THX Cinema** : Neo:6 Cinema +THX Cinema\*1
- 8 **DTS+THX Games** : DTS+THX Games\*2
- 9 **2.0 THX Games** : DTS(2 channel signals)+2.0 THX Games\*2
- 10 **DTS 96/24+THX Games** : DTS 96/24+THX Games\*2
- 11 **DTS+THX MusicMode** : DTS+THX MusicMode\*3

Continued to next page.

⑫	<b>DTS 96/24+THX MusicMode</b>	: DTS 96/24 +THX MusicMode*3
⑬	<b>DTS+THX Select2 Cinema</b>	: DTS+THX Select2 Cinema*4
⑭	<b>DTS 96/24+THX Select2 Cinema</b>	: DTS 96/24+THX Select2 Cinema*4
⑮	<b>DTS-ES Mtrx 6.1</b>	: DTS-ES Matrix 6.1*5
⑯	<b>DTS-ES Dscrt 6.1</b>	: DTS-ES Discrete 6.1*5
⑰	<b>DTS</b>	: DTS*5
⑱	<b>DTS+Neo:6 Cin</b>	: DTS+Neo:6 Cinema*5
⑲	<b>Neo:6 Cinema</b>	: Neo:6 Cinema*5
⑳	<b>Neo:6 Music</b>	: Neo:6 Music*5
㉑	<b>DTS 96/24</b>	: DTS 96/24*5
㉒	<b>Stereo</b>	: Stereo*5

**When the analog signal or the digital signal (except for Dolby Digital or DTS signal) is input :**

①	<b>PLII Movie+THX Cinema</b>	: Dolby Pro Logic II Movie mode +THX Cinema*1
②	<b>Pro Logic+THX Cinema</b>	: Dolby Pro Logic+THX Cinema*1
③	<b>Neo:6 Cinema+THX Cinema</b>	: Neo:6 Cinema+THX Cinema*1
④	<b>Stereo+THX Cinema</b>	: Stereo+THX Cinema*1
⑤	<b>2.0 THX Games</b>	: 2.0 THX Games*2
⑥	<b>PLIIx Movie</b>	: Dolby Pro Logic Iix Movie mode*5
⑦	<b>PLIIx Music</b>	: Dolby Pro Logic Iix Music mode*5
⑧	<b>PLIIx Game</b>	: Dolby Pro Logic Iix Game mode*5
⑨	<b>PLII Movie</b>	: Dolby Pro Logic II Movie mode*5
⑩	<b>PLII Music</b>	: Dolby Pro Logic II Music mode*5
⑪	<b>PLII Game</b>	: Dolby Pro Logic II Game mode*5
⑫	<b>Pro Logic</b>	: Dolby Pro Logic*5
⑬	<b>Neo:6 Cinema</b>	: Neo:6 Cinema*5
⑭	<b>Neo:6 Music</b>	: Neo:6 Music*5
⑮	<b>Stereo</b>	: Stereo*5

- \*1 THX Cinema mode only.
- \*2 THX Games mode only.
- \*3 THX MusicMode only.
- \*4 THX Select2 Cin only.
- \*5 THX OFF only.

- Dolby Digital or DTS signal having more channels than the maximum number of playback channels available using the receiver's current settings is input, downmixing is performed to match the number of available channels.

**4 Adjust the volume.**

**DSP mode**

This mode can be selected when digital signals other than Dolby Digital or DTS, or analog signal come in.  
This mode can be selected when THX mode is off.

- ① **Pressing the DSP key or DSP MODE key will display the current DSP MODE status.**
- ② **Each press of the key will switch to the next status as shown below:**

①	<b>Arena</b>	: Arena mode.
②	<b>Jazz Club</b>	: Jazz Club mode.
③	<b>Theater</b>	: Theater mode.
④	<b>Stadium</b>	: Stadium mode.
⑤	<b>Disco</b>	: Disco mode.

- The DSP mode selection is displayed for approximately 3 seconds.

**Switching the LISTEN mode to Stereo temporarily**

Pressing the **STEREO** key changes the currently selected LISTEN mode into Stereo. It will be changed back to the original LISTEN mode by pressing the **STEREO** key again.

- If the power is turned off and turned back on, or the input selector is switched to another and switched back, the LISTEN mode will be back to the original one.

Notes

- Depending on the type of the signal or speaker setting, some listening modes cannot be selected.
- When playback is started, the sound may be cut or interrupted before the input source is confirmed as Dolby Digital or DTS.
- To enjoy Dolby Digital surround (as well as all the other listening modes) from a single component, be sure to use a Dolby Digital compatible source component.
- Dialogue Normalization (Dial Norm) is a feature of Dolby Digital. It is able to automatically maintain the overall audio output level constant.



When playing some Dolby Digital sources, you may see in the display a message "DIALNORM OFFSET xxdB". This is because some soundtracks may be recorded either louder or quieter than normal. The xx number shows by how much.  
For example, if the message says "DIALNORM OFFSET +4dB" you know that this particular recording was encoded 4dB louder than normal. If you wish, you can turn down the volume control by 4dB to keep the playback level consistent.

## Virtual modes

The following modes allow you to enjoy astonishing ambience effect even when you use only two speakers or listen through headphones.

- In the Dolby Virtual Speaker and Dolby Headphone modes, the desired listen mode may be unable to be selected depending on the reproduced signals. - [37]

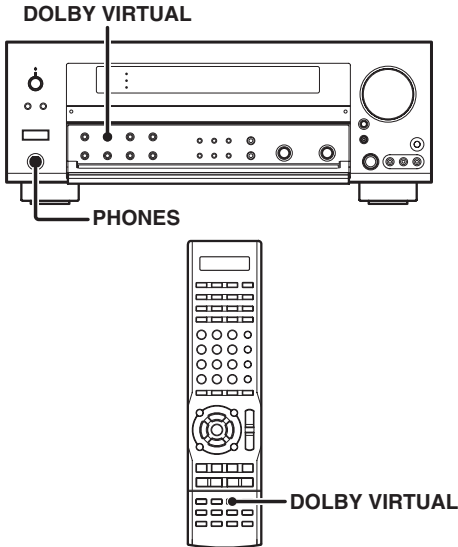

### How to set the Dolby Virtual Speaker mode (when not using headphones):

Press the **DOLBY VIRTUAL** key for the following selections:

- ① **DOLBY VS WIDE** : The virtual surround effect can be given added expansion and spatial feeling. (DOLBY VS indicator lights up)
- ② **DOLBY VS REF** : Standard setting.\* (DOLBY VS indicator lights up)
- ③ **DOLBY VS OFF** : Cancel (DOLBY VS indicator goes off)

\* This mode can be selected only when the surround speaker setting is OFF.

### How to set the Dolby Headphone mode (when using headphones):

Press the **DOLBY VIRTUAL** key for the following selections:

- ① **DOLBY H DH 1** : Monitor room in a studio with small amount of reverberations. (DOLBY H indicator lights up)
- ② **DOLBY H DH 2** : General listening with optimum amount of reverberations. (DOLBY H indicator lights up)
- ③ **DOLBY H DH 3** : Wide space such as a movie theater. (DOLBY H indicator lights up)
- ④ **DOLBY H OFF** : Cancel (DOLBY H indicator goes off)

- The Dolby Virtual Speaker will be available when the **SPEAKERS A** is ON and **SPEAKERS B** is OFF.
- Dolby Virtual Speaker is effective for sampling frequencies of 32kHz, 44.1kHz and 48kHz. Dolby Headphone is effective for sampling frequencies of 44.1kHz and 48kHz.

## DVD 6-channel playback

Using a DVD player or the like equipped with six (5.1) output channels and the receiver, you can enjoy surround sound playback.

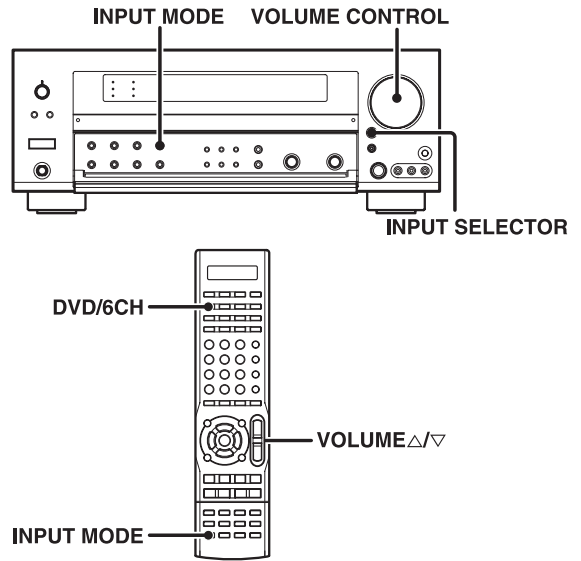

### Preparations

- Connect your DVD player to the DVD/6CH jacks of the receiver. - [10]
- Turn on all other components that will be used.
- Complete "Preparing for surround sound". - [19]

**1** Use the **INPUT SELECTOR** key or **DVD/6CH** key to select "DVD/6CH" as the input source.

**2** Select "6CH INPUT" by pressing the **INPUT MODE** key.

- If speaker system B is on when "6CH INPUT" is selected as the input mode, it switches off and speaker system A turns on automatically.
- The indication "6CH INPUT" appears in the display during DVD 6-channel mode selection.

**3** Start playback of the DVD software.

**4** Adjust the volume.

### Notes

- It is not possible to adjust the sound quality (**SETUP, SOUND, LISTEN MODE, ACTIVE EQ, THX, STEREO, DSP MODE, LOUDNESS and TONE key will not be functional**) of the channels separately when the receiver is in the 6CH INPUT mode. Adjust the volume with the controls of the DVD player. For the powered subwoofer, you can adjust the volume of the subwoofer using the subwoofer's own volume control.

## Adjusting the sound

You can make further adjustments to the sound while listening to playback in the surround mode.

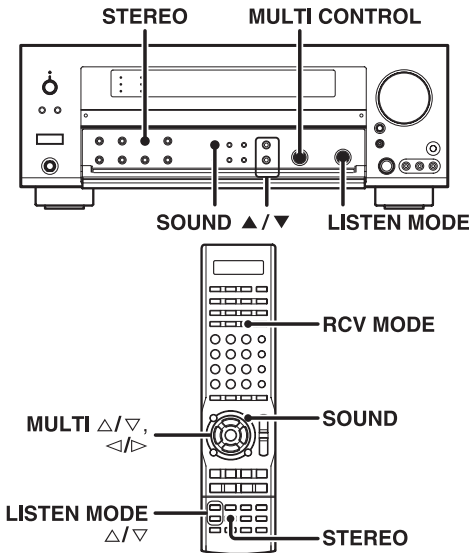

➊ For the remote control unit, press the RCV MODE key to switch to receiver mode.

➋ Press the SOUND key and then use the ▲/▼ keys or MULTI </> keys until the desired item appears in the display.

Each time you press the ▲/▼ keys or MULTI </> keys, the menu changes as follows:  
 Note that some items are not displayed depending on speaker settings and listening modes.

- ➀ CNTR (Center speaker level adjustment)\*
- ➁ SR (Surround Right speaker level adjustment)\*
- ➂ SB (Surround Back speaker level adjustment)\*
- ➃ SBR (Surround Back Right speaker level adjustment)\*
- ➄ SBL (Surround Back Left speaker level adjustment)\*
- ➅ SL (Surround Left speaker level adjustment)\*
- ➆ SUBW (Subwoofer level adjustment)\*
- ➇ INPUT (Input level adjustment - analog mode only) - 27
- ➈ MIDNIGHT (Midnight mode ON/OFF - Dolby Digital and DTS mode only)
- ➉ PANORAMA (Panorama mode ON/OFF)\*\*
- ➊ DIMENSION (Dimension adjustment)\*\*
- ➋ CENTER WIDTH (Center width adjustment)\*\*
- ➌ CENTER IMAGE (Center image adjustment - Neo:6 Music mode only)
- ➍ DUAL MONO (Dual Mono selection - Dolby Digital mode only)

\* The adjustment is only temporary for the current input selection. The value will return automatically to the original setup value when the power is turned on/off.

\*\* Pro Logic IIx Music and Pro Logic II Music mode only.

• If you have selected "SB NML/THXx1" or "SB LARGEx1", "SBR" and "SBL" are not appeared but "SB" is appeared on the Display.

➌ Use the MULTI CONTROL knob or MULTI ▲/▼ keys to adjust the setting as desired.

• The adjustment item is displayed for approximately 20 seconds.

➍ Press the SOUND key again to return to the input indication.

### Midnight mode (Dolby Digital and DTS mode only)

When watching movies at night, you might not be able to raise the volume as loud as normal. Midnight mode compresses the dynamic range of previously specified heavy sound passage of the Dolby Digital and DTS sound track (like scenes with sudden increases in volume) to minimize the difference in volume between the scenes with heavy sound passage and scenes with normal sound passage. This makes it easy to hear all of the sound track, even when listening at low volumes.

➊ Press the SOUND key, then press the ▲/▼ keys or MULTI </> keys until "MIDNIGHT" appears on the display.

• This can be selected only if CD/DVD, DVD/6CH, VIDEO 2 or VIDEO 3 is selected as the source and the input signal is set to "Dolby Digital" or "DTS".

➋ Use the MULTI CONTROL knob or MULTI ▲/▼ keys to select the ON or OFF setting.



• The adjustment item is displayed for approximately 20 seconds.  
 • Some Dolby Digital or DTS software may not be compatible with the Midnight mode.

➌ Press the SOUND key again to return to the input indication.

### Panorama mode (Pro Logic IIx Music mode and Pro Logic II Music mode only)

When listening to music, you will be able to enjoy the "wrap-around" sound effect when you adjust the panorama mode.

➊ Press the SOUND key, then press the ▲/▼ keys or MULTI </> keys until "PANORAMA" appears on the display.

➋ Use the MULTI CONTROL knob or MULTI ▲/▼ keys to select PANORAMA ON or OFF.

- ➀ PANORAMA ON : PANORAMA mode is ON.
- ➁ PANORAMA OFF : PANORAMA mode is OFF.

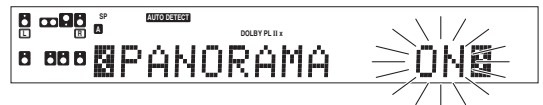

➌ Press the SOUND key again to return to the input indication.

### Dimension mode (Pro Logic IIx Music mode and Pro Logic II Music mode only)

When listening to music with certain recordings, you will also be able to achieve a suitable balance from all the speakers by adjusting the dimension mode.

- 1 Press the **SOUND** key, then press the **▲/▼** keys or **MULTI </>** keys until "DIMENSION" appears on the display.
- 2 Use the **MULTI CONTROL** knob or **MULTI ▲/▼** keys to adjust the soundfield towards the rear or the front.

Soundfield is adjusted towards the front.

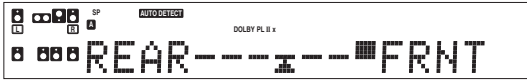

Soundfield is adjusted towards the rear.

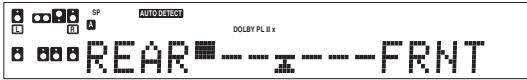

- 3 Press the **SOUND** key again to return to the input indication.

### Center Width mode (Pro Logic IIx Music mode and Pro Logic II Music mode only)

Center width adjustment allows you to enjoy an enhanced sound when listening to music through center image from only center speaker, or left and right speakers or various combinations adjustments.

- 1 Press the **SOUND** key, then press the **▲/▼** keys or **MULTI </>** keys until "CENTER WIDTH" appears on the display.
  - The CENTER WIDTH indication scrolls across the display.
  - When the center speaker is switched OFF, this mode will not be effective.
- 2 Use the **MULTI CONTROL** knob or **MULTI ▲/▼** keys to adjust the left-center-right output.

Center image will be heard from center speaker only.

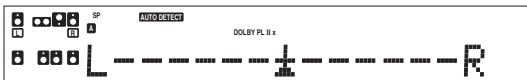

Center image will be heard from left and right speakers only.

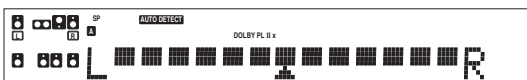

- When in other position, center image from center speaker, left and right speakers can be heard simultaneously with various combinations.

- 3 Press the **SOUND** key again to return to the input indication.

### Center Image mode (Neo:6 Music mode only)

In the CENTER IMAGE setting mode of the Neo:6 Music listen mode, it is possible to enhance the center channel audio by adjusting the center signal component.

- 1 Press the **SOUND** key, then press the **▲/▼** keys or **MULTI </>** keys until "CENTER IMAGE" appears on the display.



- When the center speaker is switched OFF, this mode will not be effective.

- 2 Use the **MULTI CONTROL** knob or **MULTI ▲/▼** keys to adjust the left-center-right output.

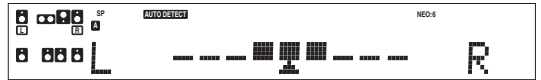

- Adjust the center component level.

- 3 Press the **SOUND** key again to return to the input indication.

### Dual Mono mode (Dolby Digital mode only)

When the Dolby Digital source have Multiplex sound, you can select Main / Sub sound for Audio output.

- 1 Press the **SOUND** key, then press the **▲/▼** keys or **MULTI </>** keys until "DUAL MONO" appears on the display.
  - This can be selected only if CD/DVD, DVD/6CH, VIDEO 2 or VIDEO 3 is selected as the source and the LISTEN mode is set to "Dolby Digital".
- 2 Use the **MULTI CONTROL** knob or **MULTI ▲/▼** keys for the following selection.

- 1 **Main** : Multiplex Main channel output.
- 2 **Sub** : Multiplex Sub channel output.
- 3 **Main + Sub** : Multiplex Main + Sub channel output.
- 4 **Stereo** : Main channel from the left speaker. / Sub channel from the right speaker.

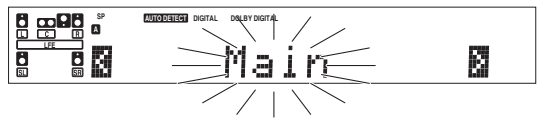

- The adjustment item is displayed for approximately 20 seconds.

- 3 Press the **SOUND** key again to return to the input indication.

### 96kHz LPCM playback

The receiver is compatible with the 96kHz LPCM playback. To play a 96kHz DVD, set the listen mode other than DSP mode. (96kHz fs indicator lights up)

- When the listen mode is set to DSP mode, the listen mode will automatically be Stereo.

## Convenient functions

### Display dimmer adjustment

The dimmer function lets you select the brightness of the receiver's display. You might find this useful if you darken your room to watch movies or listen to music.

**For the remote control unit, press the RCV MODE key to switch to receiver mode.**

**Each time you press the DIMMER key, the display brightness changes among the three available settings. Select the brightness level you find most pleasing.**

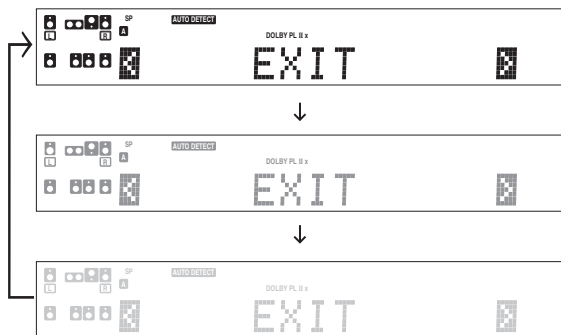

### Sleep timer

The sleep timer function turns the receiver OFF (to the standby mode) automatically when the set timer period has elapsed. The sleep timer period can be set in 10-minute steps up to 90 minutes.

**For the remote control unit, press the RCV MODE key to switch to receiver mode.**

**Press the SLEEP key repeatedly until the desired period before turning the receiver OFF (standby mode) is displayed.**

- Each press increments the sleep timer period by 10 minutes.  
**10 → 20 → 30 .....70 → 80 → 90 → Cancel → 10 → 20 → ...**

The "SLEEP" indicator lights up



- Pressing the **SLEEP** key after the sleep timer has started allows you to check the remaining time period.
- To cancel the sleep timer, turn the receiver OFF (standby mode) or press the **SLEEP** key repeatedly until the Sleep timer indicator disappears.

# Basic remote control operations for other components

The remote control supplied with this receiver is also capable of controlling components from a variety of manufacturers once you register the appropriate setup codes into the remote control unit.

### Low battery warning

Replace all two batteries with new ones when you notice a shortening of the distance from which the remote control will operate. The remote control is designed to retain setup codes in memory while you change batteries.

## Registering setup codes for other components

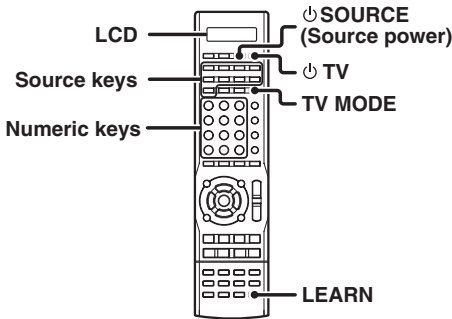

### 1 Find the setup code of the component to be registered.

- Refer to the setup code lists to find the setup code for the component to be registered. → 46

### 2 Press the Source keys (DVD/6CH, VIDEO 1, VIDEO 2, VIDEO 3, CD/DVD, MD/TAPE, PHONO, AV AUX, TV MODE).

The following table shows the type of components that can be registered in each Source key.

Source key	Other components	LCD display
TUNER	Fixed to receiver operation mode.	RCV
DVD/6CH	DVD	DVD
CD/DVD	CD and MD (Kenwood)	CD
MD/TAPE	CD and MD (Kenwood)	CD
VIDEO 1, AV AUX	VCR and PVR	VCR
VIDEO 2	Cable and DTV decoder	CABLE
VIDEO 3	Satellite Receiver	DSS
PHONO	Additional key for re-assigning	PHONO
TV MODE	TV/VCR combo, TV/DVD combo, TV	TV

- PHONO key has to be re-assigned to another key before a setup code can be registered. → 44
- While in Tuner mode, setup code function will not be available.

### 3 Press and hold the LEARN key until the LED blinks twice, then release the LEARN key.

### 4 Press the Numeric keys to enter the four-digit code for the component to be registered.

- If performed correctly, LED will blink twice.
- Point the remote control at the component and press SOURCE (Source power) key once. It should turn on/off but if it does not, repeat step 2 to 4.
- If the component still does not work, try searching for the code.

### 5 Repeat steps 2 to 4 to register additional components until all components have been registered.

#### Note

Although each setup code is designed to work with a number of different models, certain codes may not work with some models. (Also, certain codes may only operate some of the functions available on a given model.)

## Searching for your codes

If your component does not respond after trying all the codes listed for your component, or if your component is not listed at all, try searching for your code.

For example, to search for code for your TV:

### 1 Press the TV MODE key once. Next, press and hold the LEARN key until LED blinks twice, then release the LEARN key.

### 2 Press the Numeric key to enter 9, 9, 1.

- LED will blink twice.

### 3 Point the remote control at the TV and slowly alternate between pressing the TV and TV MODE key.

- Stop when the TV turns on/off.
- In the search mode, the remote control will send IR codes from its library to the selected device, starting with the most popular code first.

### 4 Press the LEARN key once to lock in the code.

### 5 To search for the codes of your other components, repeat steps 1 through 4, but substitute the appropriate key (i.e., DVD/6CH, VIDEO 1, VIDEO 2, VIDEO 3, CD/DVD, MD/TAPE, PHONO, AV AUX, TV MODE, SOURCE).

- PHONO key has to be re-assigned to another key before a setup code can be programmed.

## Checking the codes

If you have setup the remote control using the procedures described in "Searching for your codes", you may need to find out which four-digit code is operating your equipment:

For example, to find out which code is operating your TV:

### 1 Press the TV MODE key once. Next, press and hold the LEARN key until LED blinks twice, then release the LEARN key.

### 2 Press the Numeric key to enter 9, 9, 0.

- LED will blink twice.

### 3 To view the code for the first digit, press "1" once. Wait for 3 seconds, counts the number of times LED blinks (e.g., blinks=3) and write down that number.

- If a code digit is "0", the LED will not blink.

### 4 Repeat step 3 three more times for the remaining digits. Use "2" for the second digit, "3" for the third digit, and "4" for the fourth digit.

### 5 To check the codes of your other components, repeat steps 1 through 4, but substitute the appropriate key (i.e., DVD/6CH, VIDEO 1, VIDEO 2, VIDEO 3, CD/DVD, MD/TAPE, PHONO, AV AUX, TV MODE) for the component you are checking.

- As suggested earlier on, write down each of the four-digit code.
- PHONO key has to be re-assigned to another key before a setup code can be programmed.

## Re-assigning device keys

The remote control can be setup to control second TV or VCR, or any combination of eight home entertainment components.

For example, to control the operation of two different VCR using the remote control, the user need to re-assign the unused **VIDEO 2** key to operate the second VCR (VIDEO 1) as follows:

**1 Press and hold the LEARN key until  blinks twice, then release the LEARN key.**

**2 Press the Numeric key to enter , , .**

-  will blink twice.

**3 Press VIDEO 1 key once, then press the VIDEO 2 key once.**

- The user now can operate VIDEO 2 as a second VCR along with VIDEO 1.
- Refer to the table in the previous page for the combination of source keys and the other components assignment.

**4 To re-assign other device keys, repeat steps 1 through 3 by substituting the key sequence from the below chart for the most popular components:**

To re-assign key



Sequence	Perform
TV MODE as 2nd VIDEO 1 key LEARN	9 9 2 VIDEO 1 TV MODE
TV MODE as 2nd VIDEO 2 key LEARN	9 9 2 VIDEO 2 TV MODE
TV MODE as 2nd CD/DVD key LEARN	9 9 2 CD/DVD TV MODE
TV MODE back to TV MODE key LEARN	9 9 2 TV MODE TV MODE
VIDEO 1 as 2nd TV MODE key LEARN	9 9 2 TV MODE VIDEO 1
VIDEO 1 as 2nd VIDEO 2 key LEARN	9 9 2 VIDEO 2 VIDEO 1
VIDEO 1 as 2nd CD/DVD key LEARN	9 9 2 CD/DVD VIDEO 1
VIDEO 1 back to VIDEO 1 key LEARN	9 9 2 VIDEO 1 VIDEO 1

**5 To clear the re-assignment and reset the remote control to its original operation mode:**

**1 Press and hold the LEARN key until  blinks twice, then release the LEARN key.**

**2 Press the Numeric key to enter , , .**

**3 Press VIDEO 2 key twice.**

- When a re-assignment is done,  will blink twice to confirm your choice. At that time, you will need to program the remote control in order to control the new component.
- If an invalid key sequence is entered,  blink once and return to normal operation.
- When in Tuner mode, re-assignment is not available.

## Operating other components

This operation lets you operate the registered components.

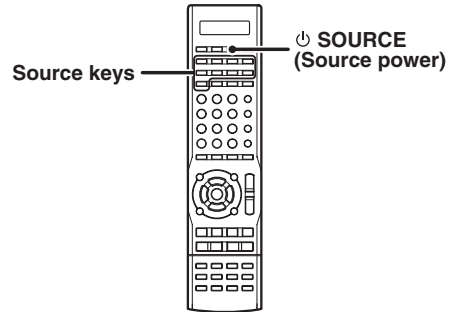

**1 Use the Source keys to select the component you desire.**

- Pressing the source keys also changes the input selector on the receiver.

**2 Press the  SOURCE key.**





- To return to the receiver operation mode, press the **RCV MODE** key.

**3 Press the operation keys you desire.**

→ 

**The remote control mode remains at the selected input. If you wish to operate another component, repeat step 2 or 3.**

### Resetting the Remote Control

- To initialize the remote control, press the **LEARN** key until the  blinks twice. Then press the Numeric key to enter , , . The  will blink twice.

## Storing the remote control code of the other components

The remote control unit can store the remote control code of the other components and you can operate the other components from the remote control unit. The remote control code is stored on the key or memory of the remote control unit.

### Storing on the key

You can store the remote control code to the key as shown below:

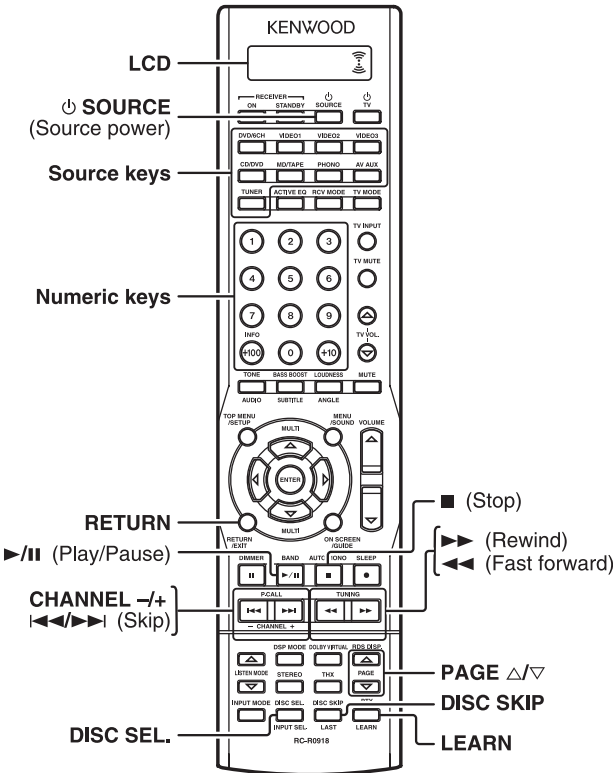

- 1 Point the transmitting part of infrared ray of another remote control unit to the receiving part of the remote control unit.

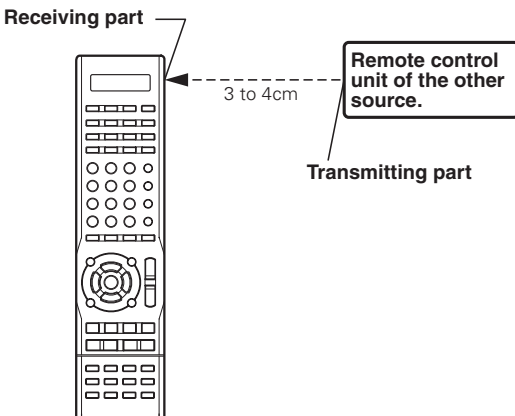

- 2 Press and hold the LEARN key for 3 seconds until blinks twice, then release the LEARN key.

- 3 Press the Numeric key to enter **9**, **7**, **5**.

- 4 Press any of the Source keys (DVD/6CH, VIDEO 1, VIDEO 2, VIDEO 3, CD/DVD, PHONO, AV AUX, MD/TAPE, TV MODE) to select the input of the desired remote control unit.

- While in Tuner mode, learning code function is not available.

- 5 Press the desired key of the remote control unit.

- "LEARN" and appear on the display.

- 6 From the remote control unit of the other source, press the key that you want to store.

- The remote control code is sent to the remote control unit.
- "OK" appears when finished.
- If the code cannot be stored after a few attempts, "ERROR" will appear. Repeat from step 2 onwards.

- 7 The remote control code is stored on the key of this remote control unit.

- 8 Repeat step 4 to 6 to store additional components until all the desired components are stored.

- 9 To exit the learning mode, press and hold the LEARN key for 3 seconds until blinks twice.

- 10 To clear the stored remote control code of the other sources:

- 1 Press and hold the LEARN key for 3 seconds until blinks twice, then release the LEARN key.

- 2 Press the Numeric key to enter **9**, **7**, **6**.

- 3 Press the Source key, then press the stored key twice until blinks twice.

- blinks twice to indicate that the stored remote control code is deleted.

## Setup code chart

## DVD player

Maker	Setup codes
Allegro	0869
Ap3DLAB	0539
A-Trend	0714
Acoustic Solutions	0730
AEG	0770, 0788, 0790
Afreey	0698
Aim	0699
Aiwa	0533, 0641, 1912
Akai	0690, 0705, 0716, 0766, 0788, 0790, 1115
Akira	0699
Akura	0898, 1170
Alba	0539, 0672, 0695, 0699, 0713, 0717, 0730, 0783
Alize	1151
Amitech	0770, 0850
Amstrad	0713
AMW	0872
Ansonic	0831
Apex Digital	0672, 1004
Audiosonic	0690
Audiovox	0717
Awa	0730, 0872
Axion	0730
Baze	0672
Beko	1153
Bellagio	1004
Black Diamond	0713, 0766
Blue Sky	0651, 0672, 0695, 0713
Boghe	1004
Boman	0783
Brainwave	0770, 1115
Brand Unknown	0490, 0717, 0730
Brandt	0503, 0551, 0651
Broksonic	0695
Bush	0516, 0672, 0690, 0695, 0699, 0713, 0717, 0730, 0831
C-Tech	0768
Cambridge Audio	0751
Cat	0699
CCE	0730
Centrex	0672, 1004
Centrum	0713
CGV	0751, 1115
Cinetec	0713, 0872
cineULTRA	0699
Classic	0730
Clatronic	0672, 0788
Clayton	0713
Coby	0730
Compacts	0826
Conia	0516, 0672, 0852
Contel	0788
Continental Edison	0831, 0872
Crown	0690, 0770, 1115
Cybercom	0831
CyberHome	0714
Cytron	0651, 0705, 0716
D-Vision	1115
Daewoo	0705, 0714, 0770, 0872
Daewoo International	0872

## DVD player (Continued)

Maker	Setup codes
Dansai	0770, 0783, 1115
Dantax	0723, 0790
Daytek	0872
Dayton	0872
DCE	0831
Decca	0770, 1115
Denon	0490, 1634
Denver	0672, 0699, 0788, 0898
Denzel	0665
Diamond	0651, 0751, 0768
Digihome	0713
digiRED	0717
Digitor	0651
Digitrex	0672
DIGIXmedia	0826
DiK	0831
Dinamic	0788
DiViDo	0705
DK digital	0831
DMTECH	0783
Dragon	0831
DreamX	1151
Dual	0651, 0665, 0713, 0730, 0783, 0790, 0831
Durabrand	0713
DVX	0768
Eclipse	0723, 0751
Elin	0770
Ellion	0850
Elta	0672, 0690, 0770, 0788, 0850, 1115, 1151
Eltax	0766
Emerson	0591, 0705
Encore	0698
Enterprise	0591
Enzer	0766
EuroLine	0788, 1115
Fenner	0651
Ferguson	0651
Finlux	0591, 0672, 0741, 0751, 0770, 0783
Firstline	0713
Fisher	0670
Funai	0695
GE	0717
Global Solutions	0768
Global Sphere	0768
Go Video	0783
GoldStar	0591, 0741
Goodmans	0651, 0690, 0713, 0723, 0730, 0783, 0790, 1004
GPX	0699
Graetz	0665
Gran Prix	0831, 0898
Grandin	0713, 0716
Greenhill	0717
Grundig	0539, 0551, 0651, 0670, 0695, 0705, 0713, 0723, 0775, 0790, 1004
Grunkel	0770
H & B	0850
H&B	0713, 0850
Haaz	0751, 0768

## DVD player (Continued)

Maker	Setup codes
Hanseatic	0741, 0783, 1153
Harman/Kardon	0702
HCM	0788
HDT	0705
HE	0730
HenØ	0713
Hitachi	0573, 0664
Hiteker	0672
Home Electronics	0730
Humax	0646
Hyundai	0783, 0850
H_er	0651, 0713, 0826, 0831
ICP	1153
Ingelen	0788
InterAct	0697
IRT	0783
ISP	0695
Jaton	0665
JDB	0730
Jeken	0699
JMB	0695
JVC	0503, 0539, 0558, 0623, 1164, 1901, 1940, 1988
Karcher	0783
Kendo	0699, 0713
Kennex	0770
Kenwood	0490, 0534
Kiirō	0770
Kiss	0665
Lawson	0716, 0768
Lenco	0651, 0672, 0699, 0713, 0770
Lenoxx	0690
Lexia	0699, 0768
LG	0591, 0741, 1906
Lifetec	0651, 0831
Limit	0716, 0768
Loewe	0539, 0885
Logix	0705, 0783
Lumatron	0705
Luxman	0573
Luxor	1004
Mad Catz	1002, 1108
Magnavox	0503
Magnex	0723
Manhattan	0705, 0713
Marantz	0539
Mark	0713
Marquant	0770
Matsui	0651, 0672, 0695, 0713, 1004
Maxdorf	0788
Maxim	0713
MBO	0690, 0730
Mecotek	0770
Medion	0630, 0651, 0716, 0783, 0831
Memorex	0831
Metronic	0690
Metz	0525, 0571, 0713
MICO	0723, 0751, 1179
Micromedia	0503, 0539

## Setup code chart

## DVD player (continued)

Maker	Setup codes
Micromega	0539
Microsoft	0522
Microstar	0831
Minato	0752
Minax	0713
Minerva	0705
Minoka	0770
Mirror	0752
Mitsubishi	0713
Monyka	0665
Mustek	0730
Mx Onda	0651, 0751, 1179
NAD	0741
Naiko	0770, 1004
Neufunk	0665
Nevir	0770, 0831
Nordmende	0831
Noriko	0752
NU-TEC	0516
Okano	0752
Olidata	0672
Omni	0690, 0698
Onkyo	0503, 0612, 0627, 1924
Optimus	0525
Orion	0695
Oritron	0651
Ormond	0713
Otic	0826
Pacific	0713, 0768, 0790, 0831
Palladium	0695
Palsonic	0672, 0852
Panasonic	0490, 1907, 1908, 1910, 1909
Panda	0717
Pelican	0731
Philco	0690, 0788
Philips	0503, 0539, 0646, 1914
Phonotrend	0699
Pioneer	0525, 0571, 0631, 0638, 1900, 1902, 1965
Plu2	0850
Powerpoint	0872
Prima	0766
Prima Electronic	0766
Prinz	0831
Prism	0705
Proline	0651, 0672, 1004
Proscan	0522
Prosonic	0699
ProVision	0699
Radionette	0741
Raite	0665
RCA	0522
REC	0490, 0766
Red Star	0770, 0788, 0898
Redstar	0898
Reoc	0752, 0768
Revoy	0699
Roadstar	0672, 0690, 0699, 0713, 0730
Ronin	0872
Rotel	0558, 0623

## DVD player (continued)

Maker	Setup codes
Rowa	0516, 0717, 0872, 1004
Saba	0551, 0651
Saitek	0731
Saivod	0831
Salora	0741
Sampo	0698, 0752
Samsung	0490, 0573, 0744, 1932
Sansui	0695, 0716, 0751, 0768, 1153
Sanyo	0670
Scan	0705, 0850
ScanMagic	0730
Schaub Lorenz	0770, 0788, 1115, 1151
Schneider	0539, 0651, 0705, 0783, 0788, 0790, 0831, 1153
Schwaiger	0752
Scientific Labs	0768
Scott	0651, 0672, 1036
SEG	0665, 0713, 0768, 0872
Shanghai	0672
Sharp	0630, 0752
Sherwood	0717, 0741
Shinco	0717
Silva	0788, 0898
Silva Schneider	0831, 0898
Simaudio	0885
Singer	0690, 0716, 0751, 0768
Skymaster	0730, 0768
Skysonic	0766
Skyworth	0766
Slim Devices	0533
SM Electronic	0690, 0730, 0768
Smart	0705, 0713
Sonashi	0716, 0831
Sonic Blue	0783
Sony	0533, 0573, 0772, 0864, 1070, 1633, 1903, 1934, 1981
Soundmaster	0768
Soundmax	0768
Soundwave	0783
Spectra	0872
Standard	0651, 0768, 0788
Sunkai	0770, 0850
Sunwood	0788, 0898
Supervision	0768
SVA	0672
Synn	0768
Tandberg	0713
Tatung	0770
Teac	0516, 0571, 0717, 0741, 0768, 0790
Tec	0898
Technics	0490, 1905
Technika	0770, 0831, 1115
Technisson	1115
Technosonic	1115
Techwood	0713
Tedelex	0690
Telefunken	0790
Teletech	0713, 0768
Tensai	0651, 0690, 0770

## DVD player (continued)

Maker	Setup codes
Tevion	0651, 0768, 1036
Theta Digital	0571
Thomson	0522, 0551
Thrustmaster	0498
Tokai	0665, 0698, 0788, 0790, 0898
Tokaido	0698
Tokiwa	0716
Toshiba	0503, 1045, 1988
Trans Continens	0826
TRANS-continents	0826, 0831, 0872
Trasonic	0672
Umax	0690, 1151
United	0672, 0730, 0788, 0826, 1115
Universum	0591, 0713, 0741
Venturer	0790
Vestel	0713
Vieta	0705
Voxson	0690, 0730, 0831
Waitec	1151
Walkvision	0717
Welkin	0831
Wellington	0713
Wesder	0699
Wharfedale	0698, 0751, 0752, 0790
Wilson	0831
Windy Sam	0573
WIZE	1115
Woxter	1151
Xbox	0522
Xenius	0790
XLogic	0768
XMS	0788
Yakumo	1004
Yamada	0872, 1004, 1151
Yamaha	0490, 0539, 0646
Yamakawa	0665, 0872
Yukai	0730
Zenith	0503, 0591, 1135

## Setup code chart

## TV

Maker	Setup codes
A.R. Systems	0374, 0455
Accent	0009
Acec	0012
Acura	0009
Admiral	0087, 0093, 0163, 0264
Agashi	0264
AGB	0516
Agef	0087
Aiko	0009, 0264
Aim	0037, 0455, 0706
Aiwa	0701, 1916
Akai	0009, 0037, 0072, 0163, 0178, 0208, 0218, 0264, 0361, 0371, 0377, 0433, 0473, 0480, 0516, 0548, 0556, 0602, 0606, 0631, 0648, 0696, 0714, 0715
Akiba	0037, 0218, 0282, 0294, 0455
Akira	0190, 0418
Akito	0037
Akura	0009, 0037, 0218, 0264, 0282, 0412, 0668, 0714
Alba	0009, 0036, 0037, 0163, 0218, 0247, 0355, 0371, 0418, 0443, 0487, 0668, 0714, 1037
Allorgan	0206, 0294
Allstar	0037
Amplivision	0370
Amstrad	0009, 0037, 0218, 0264, 0371, 0412, 0433, 0516, 0648, 1037
Anam	0009
Anglo	0009, 0264
Anitech	0009, 0037, 0282
Ansonic	0009, 0104, 0370, 0668
Apollo	0473
Arc En Ciel	0109, 0196, 0198
Ardem	0037, 0714
Aristona	0012, 0037, 0556
Arthur Martin	0163
ASA	0070, 0087, 0104
Asberg	0037
Asora	0009
Astra	0037
Asuka	0218, 0264
ATD	0698
Atlantic	0037, 0206, 0259
Atori	0009
Auchan	0163
Audiosonic	0009, 0037, 0109, 0218, 0264, 0337, 0370, 0374, 0486, 0714, 0715
Audioton	0264, 0370, 0486
Autovox	0087, 0206, 0247
Awa	0009, 0011, 0036, 0108, 0264, 0374, 0606
Axxent	0009
Baird	0072, 0073, 0190, 0193, 0208
Bang & Olufsen	0087, 0565
Basic Line	0009, 0037, 0218, 0282, 0374, 0455, 0556, 0668, 1037

## TV (continued)

Maker	Setup codes
Baur	0009, 0037, 0361, 0455, 0512, 0535
Beaumarck	0178
Beko	0037, 0370, 0418, 0486, 0606, 0714, 0715, 1037
Beon	0037, 0418
Berthen	0668
Best	0337
Bestar	0037, 0370, 0374
Bestar-Daewoo	0374
Black Diamond	1037
Black Star	0247
Blacktron	0282
Blackway	0218, 0282
Blaupunkt	0036, 0170, 0195, 0200, 0327, 0328, 0455, 0535
Blue Sky	0037, 0218, 0282, 0455, 0487, 0556, 0668, 0714, 0715, 1037
Blue Star	0282
Bondstec	0247
Boots	0009
BPL	0037, 0282
Brandt	0109, 0196, 0198, 0335, 0560, 0625
Brinkmann	0037, 0418, 0486, 0519, 0668
Brionvega	0087
Bruns	0087
BSR	0163, 0294
BTC	0218
Bush	0009, 0036, 0037, 0208, 0218, 0264, 0282, 0294, 0355, 0361, 0371, 0374, 0487, 0519, 0556, 0661, 0668, 0698, 0714, 1037
Canton	0218
Capsonic	0264
Carad	0610, 0668, 1037
Carena	0037, 0455
Carrefour	0036, 0070
Carver	0170
Cascade	0009, 0037
Casio	0037
Cathay	0037
CCE	0037
Centrex	0780, 0826
Centrum	1037
Centurion	0037
Century	0087, 0247
CGE	0074, 0084, 0247, 0370, 0418
Cimline	0009, 0218
Cinex	0648
City	0009
Clarivox	0037, 0070
Clatronic	0009, 0037, 0218, 0247, 0264, 0370, 0371, 0579, 0714
Clayton	1037
Concorde	0009
Condor	0009, 0037, 0247, 0264, 0282, 0370, 0418
Conrac	0808
Contec	0009, 0036, 0037

## TV (continued)

Maker	Setup codes
Continental Edison	0109, 0196, 0198, 0487
Cosmel	0009, 0037, 0337
Crosley	0074, 0084, 0087, 0247
Crown	0009, 0037, 0208, 0370, 0412, 0418, 0486, 0487, 0579, 0606, 0712, 0714, 0715
CS Electronics	0218, 0247
CTC	0247
Cybertron	0218
D-Vision	0037, 0556
Daewoo	0009, 0037, 0218, 0374, 0499, 0556, 0634, 0661, 1909
Dainichi	0218
Dansai	0009, 0036, 0037, 0208
Dansette	0412
Dantax	0714, 0715
Dawa	0009, 0037
Dayton	0009
Daytron	0009, 0037, 0374
De Graaf	0208, 0548
Decca	0037, 0072, 0516, 0621
Deitron	0374
Denko	0264
Denver	0037
DER	0190, 0193
Desmet	0009, 0037, 0087
Diamant	0037
Diamond	0009, 0264, 0371, 0698, 0706
Digatron	0037
Digiline	0668
Digital Life	0780
Digitor	0037
Dixi	0009, 0037, 0087
DL	0780
Domeos	0668
DTS	0009
Dual	0037, 0259, 0519, 0631, 1137
Dumont	0070, 0087
Dux	0012, 0037
Dynatron	0012, 0037
E-Elite	0218
Ecco	0706
Edison-Minerva	0487
Elbe	0259, 0516, 0610
Elbe-Sharp	0516
Elekta	0009, 0264, 0282
ELG	0037
Elin	0009, 0037, 0104, 0361, 0548
Elite	0218
Elta	0009, 0264
Emco	0247
Emerson	0037, 0070, 0087, 0178, 0247, 0282, 0361, 0370, 0371, 0486, 0714, 1909
Emperor	0282
Erres	0012, 0037
ESC	0037
Etron	0009, 0163
Eurofeel	0264

## Setup code chart

## TV (continued)

Maker	Setup codes
Euroman	0037, 0264, 0370
Europa	0037
Europhon	0516
Expert	0163, 0206, 0259
Exquisit	0037, 0247
Fenner	0009, 0374
Ferguson	0037, 0073, 0109, 0190, 0193, 0335, 0548, 0560, 0625
Fidelity	0037, 0163, 0193, 0264, 0361, 0371, 0412, 0512
Finlandia	0072, 0163, 0208, 0346, 0548
Finlux	0037, 0070, 0072, 0087, 0104, 0346, 0473, 0480, 0516, 0621, 0629, 0631, 0714, 0715
Firstline	0009, 0037, 0072, 0208, 0247, 0294, 0361, 0374, 0556, 0668, 0714, 1037
Fisher	0036, 0072, 0087, 0104, 0208, 0370
Flint	0037, 0072, 0218, 0264, 0455, 0610
Forgestone	0193
Formenti	0037, 0087
Fortress	0087, 0093
Fraba	0037, 0370
Friac	0009, 0037, 0370, 0499, 0610
Frontech	0009, 0163, 0247, 0264
Fujitsu	0009, 0072, 0206, 0259
Fujitsu General	0009, 0206
Funai	0264, 0294, 0668
Futronic	0264
Galaxi	0037
Galaxis	0037, 0370
GBC	0009, 0218, 0374
GE	0093, 0178, 0282, 0560, 0625
GEC	0037, 0072, 0163, 0361, 0516
Geloso	0009, 0374
General Technic	0009
Genesis	0009, 0037
Genexxa	0009, 0037, 0163, 0218, 0412
Goldfunk	0668
GoldStar	0037, 0109, 0163, 0178, 0247, 0361, 0377, 0606, 0714, 0715
Gooding	0487
Goodmans	0009, 0036, 0037, 0072, 0218, 0264, 0335, 0371, 0374, 0480, 0487, 0499, 0516, 0556, 0560, 0579, 0634, 0661, 0668, 0714, 1037, 1909
Gorenje	0370
GPM	0218
Gradiente	0170
Graetz	0163, 0361, 0371, 0487
Gran Prix	0648
Granada	0037, 0072, 0108, 0163, 0208, 0226, 0473, 0516, 0548, 0560
Grandin	0009, 0037, 0163, 0282, 0374, 0455, 0579, 0610, 0668, 0714, 0715, 1037

## TV (continued)

Maker	Setup codes
Grundig	0009, 0036, 0037, 0070, 0195, 0443, 0487, 0535, 0556, 0587, 0706
Haaz	0706
Haier	0698
Halifax	0264
Hanimex	0218, 0294
Hanseatic	0009, 0037, 0087, 0282, 0294, 0361, 0377, 0499, 0519, 0556, 0634, 0661, 0714, 0808
Hantarex	0009, 0037, 0516
Hantor	0037
Harwood	0009, 0037, 0412, 0487
Hauptpaue	0037
Havermy	0093
HCM	0009, 0037, 0218, 0264, 0282, 0412, 0418
Hema	0009
Hifivox	0109, 0196, 0198
Highline	0037, 0264
Hikona	0218
Hinari	0009, 0036, 0037, 0218, 0264, 0294, 0355
Hisawa	0218, 0282, 0455, 0610, 0714
Hisense	0009, 0208, 0508, 0780
Hit	0087
Hitachi	0036, 0037, 0072, 0108, 0109, 0163, 0194, 0196, 0198, 0225, 0473, 0480, 0499, 0516, 0548, 0578, 0629, 0634, 0719, 0730, 0744, 1037, 1137, 1481
Hitachi Fujian	0108
Hitsu	0009, 0218, 0455, 0610
HMV	0087, 0193
Home Electronics	0606
Hornymphon	0012, 0037
Hoshai	0282
Huanyu	0374
Hyper	0009, 0247
Hypson	0037, 0264, 0282, 0455, 0621, 0668, 0714, 0715, 1037
H_er	0714
Iberia	0037
ICE	0218, 0264, 0371
ICeS	0218
Imperial	0037, 0074, 0084, 0196, 0247, 0370, 0418
Indiana	0037
Ingelen	0163, 0487, 0610, 0714
Ingersoll	0009
Inno Hit	0009, 0072, 0247, 0282, 0516
Innovation	0519
Interbuy	0037, 0247, 0264
Interfunk	0012, 0037, 0087, 0163, 0200, 0247, 0327, 0361, 0512
Internal	0037
Intervision	0009, 0037, 0218, 0247, 0264, 0282, 0377, 0455, 0486, 0487, 0519

## TV (continued)

Maker	Setup codes
IR	0011, 0012, 0036, 0037, 0070, 0072, 0073, 0087, 0093, 0104, 0108, 0109, 0163, 0190, 0193, 0194, 0195, 0196, 0200, 0206, 0225, 0226, 0247, 0294, 0327, 0361, 0370, 0374, 0512, 0516, 0535, 0556
Irradio	0009, 0037, 0218, 0247, 0371
Isukai	0037, 0218, 0282, 0455
ITS	0037, 0218, 0264, 0282, 0371
ITT	0163, 0193, 0208, 0346, 0361, 0473, 0480, 0548, 0610
ITT Nokia	0163, 0208, 0346, 0361, 0473, 0480, 0548, 0606, 0610
ITV	0037, 0247, 0264, 0374
Jean	0036
JMB	0443, 0499, 0556, 0634
Jocel	0712
Jubilee	0556
JVC	0036, 0093, 0190, 0193, 0218, 0371, 0418, 0606, 0653
Kaisui	0009, 0037, 0218, 0282, 0455
Kapsch	0104, 0163, 0206, 0361
Karcher	0264, 0282, 0610, 0714
Kathrein	0556
Kawa	0371
KB Aristocrat	0163
Kendo	0037, 0247, 0294, 0519, 0610
Kennedy	0163, 0206
Kiota	0455
Kioto	0706
Kiton	0037, 0668
Kneissel	0037, 0259, 0374, 0499, 0556, 0610
Kolster	0247
Konichi	0009
Konka	0037, 0218, 0371, 0418, 0587, 0714
Kontakt	0487
Korpel	0037
Korting	0087
Kotron	0412
Koyoda	0009
Kriesler	0012
Kyoshu	0412, 0418
Kyoto	0163
L&S Electronic	0714, 0808
LaSAT	0486
Leader	0009
Lecson	0037
Legend	0009
Lenco	0037, 0374
Lenoir	0009
Lesa	0247
Leyco	0037, 0072, 0264, 0294, 0579
LG	0037, 0109, 0178, 0556, 0698, 0714, 0715
Liesenk & Tter	0037

## Setup code chart

## TV (continued)

Maker	Setup codes
Liesenkotter	0012, 0037, 0327, 0328
Lifetec	0009, 0037, 0218, 0374, 0519, 0668, 0714, 1037, 1137
Lloyd's	0009
Loewe	0037, 0087, 0512, 0516, 0633, 0655
Logik	0009, 0011, 0193, 0371, 0698
Logix	0668
Luma	0206, 0259
Lumatron	0037, 0073, 0163, 0206, 0259, 0264
Lux May	0009, 0037
Luxman	0579
Luxor	0163, 0194, 0208, 0361, 0473, 0480, 0548, 0631, 1037
M Electronic	0009, 0037, 0104, 0109, 0163, 0346, 0374, 0480
Madison	0037
Magnadyne	0087, 0247, 0516
Magnafon	0516
Magnavox	0011, 0036, 0780
Magnum	0037, 0648, 0714, 0715
Mandor	0264
Manesth	0037, 0264, 0294
Manhattan	0037, 0668, 1037
Marantz	0037, 0412, 0556
Marelli	0087
Mark	0009, 0037, 0374, 0714, 0715
Master's	0499
Masuda	0009, 0037, 0218, 0264, 0371
Matsui	0009, 0011, 0036, 0037, 0072, 0163, 0195, 0208, 0294, 0335, 0355, 0371, 0433, 0443, 0455, 0487, 0516, 0556, 0579, 0629, 0714, 1037
MCE	0009
Mediator	0012, 0037
Medion	0037, 0512, 0556, 0668, 0698, 0714, 0808, 1037, 1137
Megas	0610
MEI	1037
Meletronic	0009, 0037, 0104, 0163, 0247, 0346, 0374, 0480, 0512, 0634, 0661, 0714
Memorex	0009, 0178, 1037
Memphis	0337
Mercury	0009, 0037
Metronic	0625
Metz	0037, 0087, 0367, 0447, 0535, 0587, 0668, 0746
MGA	0178, 0218, 0374
Micromaxx	0037, 0668, 0808, 1037
Microstar	0808
Minato	0037
Minerva	0070, 0108, 0487, 0516, 0535
Minoka	0037, 0412
Mistral Electronics	0193
Mitsubishi	0036, 0037, 0087, 0093, 0108, 0178, 0512, 0535, 0556, 1037

## TV (continued)

Maker	Setup codes
Mivar	0516, 0609
Monaco	0009
Morgan's	0037
MTC	0370, 0512
MTlogic	0714
Multibroadcast	0193
Multitec	0037, 0486, 0668, 1037
Multitech	0009, 0037, 0247, 0264, 0486
Murphy	0163
Musikland	0218, 0247
Myryad	0556
NAD	0178, 0361
Naiko	0037, 0606
NAT	0226
National	0226
NEC	0009, 0011, 0036, 0170, 0374, 0455, 0499, 0661
Neckermann	0037, 0087, 0200, 0247, 0327, 0370, 0418, 0556
NEI	0037, 0337, 0371
Nesco	0247
Netsat	0037
Network	0337
Neufunk	0009, 0037, 0218, 0556, 0610, 0714
New Tech	0009, 0037, 0556
New World	0218
Nikkai	0009, 0036, 0037, 0072, 0218, 0264, 0337
Nikko	0178
Noblisko	0070
Nogomatic	0109, 0196
Nokia	0163, 0208, 0346, 0361, 0374, 0473, 0480, 0548, 0606, 0610, 0631
Nordmende	0037, 0109, 0195, 0196, 0198, 0560, 0714
Normerel	0037
Novak	0012
Novatronic	0037, 0374
NU-TEC	0455, 0698
Oceanic	0163, 0208, 0361, 0473, 0548
Odeon	0264
Okano	0009, 0037, 0370
Omega	0264
Omni	0698, 0780, 0826
Onimax	0714
Onwa	0218, 0371, 0433, 0602
Opera	0037
Orbit	0037
Orion	0011, 0037, 0264, 0294, 0355, 0412, 0443, 0516, 0556, 0655, 0714, 1916
Orline	0037, 0218
Ormond	0668, 1037
Orsowe	0516
Osaki	0037, 0072, 0218, 0264, 0355, 0374, 0412, 0556
Osio	0037
Oso	0218
Osume	0036, 0037, 0072, 0218

## TV (continued)

Maker	Setup codes
Otto Versand	0036, 0037, 0093, 0109, 0226, 0247, 0294, 0361, 0512, 0535, 0556
Pacific	0556, 0714, 1037, 1137
Palladium	0037, 0247, 0370, 0418, 0519, 0655, 0714, 1137
Palsonic	0037, 0218, 0264, 0377, 0418, 0698
Panama	0037, 0247, 0264
Panasonic	0037, 0108, 0163, 0226, 0361, 0367, 0516, 0548, 0650
Panavision	0037
Pathe Cinema	0163
Pathe Marconi	0196, 0198
Pausa	0009
Penney	0178
Perdio	0037, 0072, 0163, 0282
Perfekt	0037
Philco	0037, 0074, 0084, 0087, 0247, 0370, 0418
Philex	0193
Philips	0009, 0012, 0037, 0087, 0193, 0200, 0361, 0374, 0556
Phoenix	0037, 0087, 0486
Phonola	0012, 0037, 0087, 0193
Pioneer	0011, 0037, 0109, 0163, 0170, 0361, 0486, 0512
Pionier	0370, 0486
Plantron	0009, 0037, 0264
Playsonic	0037, 0714, 0715
Polytron	0282, 0697
Poppy	0009
Portland	0374
Powerpoint	0037, 0487
Prandoni-Prince	0361, 0516
Premier	0009, 0264
Prima	0009, 0264, 0412
Prinston	1037
Prinz	0072, 0194, 0361
Profex	0009, 0163, 0361
Profi	0009
Profitronic	0037
Proline	0012, 0037, 0072, 0621, 0625, 0634
Prosonic	0037, 0370, 0371, 0374, 0579, 0668, 0714
Protech	0009, 0037, 0247, 0264, 0337, 0418, 0486, 0668, 1037
Proton	0178
ProVision	0037, 0556, 0714
Pye	0012, 0037, 0087, 0374, 0412, 0556
Pymi	0009
Quadral	0218
Quasar	0009, 0247
Quelle	0011, 0037, 0070, 0074, 0084, 0104, 0200, 0327, 0328, 0361, 0512, 0535, 0668
Questa	0036
R-Line	0037
Radialva	0218, 0337
Radiola	0012, 0037, 0556

## Setup code chart

## TV (continued)

Maker	Setup codes
Radiomarelli	0037, 0087, 0516
RadioShack	0037, 0178
Radiotone	0009, 0037, 0264, 0412, 0579, 0648, 0668, 1037
Rank	0070
Rank Arena	0036, 0602
RBM	0070
RCA	0093, 0560, 0625
Recor	0037, 0418
Rectiligne	0037
Rediffusion	0036, 0346, 0361, 0548
Reflex	0037, 0668, 1037
Reec	0714
Revovox	0037
Rex	0163, 0206, 0259, 0264
RFT	0037, 0072, 0087, 0264
Roadstar	0009, 0037, 0218, 0264, 0282, 0418, 0668, 1037
Robotron	0087
Rowa	0009, 0264, 0587, 0698, 0712
Royal Lux	0335, 0370, 0412
Saba	0087, 0109, 0163, 0196, 0198, 0335, 0361, 0516, 0548, 0560, 0625, 0714
Sagem	0455, 0610
Saisho	0009, 0011, 0264, 0516
Saivod	0037, 0668, 0712, 1037
Sakan	0163
Sakyno	0455
Salora	0163, 0194, 0208, 0361, 0480, 0516, 0548, 0621, 0631
Salsa	0335
Sambers	0516
Samsung	0009, 0037, 0072, 0093, 0163, 0178, 0208, 0264, 0370, 0519, 0556, 0587, 0618, 0644, 0718
Sansui	0037, 0371, 0455, 0602, 0655, 0706
Santon	0009
Sanyo	0011, 0036, 0072, 0104, 0108, 0208, 0370
SBR	0012, 0037, 0193, 0556
Schaub Lorenz	0361, 0374, 0486, 0548, 0606, 0714
Schneider	0012, 0037, 0070, 0163, 0218, 0247, 0259, 0361, 0371, 0519, 0556, 0648, 0668, 0714, 1037, 1137
Scotch	0178
Scotland	0163
Sears	0178
Seaway	0634
Seelver	1037
SEG	0009, 0036, 0037, 0218, 0264, 0634, 0668, 1037
SEI	0037, 0087, 0163, 0206, 0294, 0516
Sei-Sinudyne	0037, 0087, 0206, 0294, 0516
Seleco	0163, 0206, 0259, 0264, 0346, 0371
Sencora	0009
Serino	0093, 0455, 0610

## TV (continued)

Maker	Setup codes
Sharp	0036, 0093, 0193, 0200, 0294, 0516, 1193
Shintoshi	0037
Shivaki	0037, 0178, 0443
Shorai	0294
Show	0009, 0072, 0418
Siarem	0087, 0516
Siemens	0037, 0195, 0200, 0327, 0328, 0535
Siera	0012
Siesta	0370
Silva	0037, 0361, 0648
Silva Schneider	0037
Silver	0036, 0361, 0455, 0715
Singer	0009, 0037, 0087, 0335, 0433
Sinudyne	0037, 0087, 0163, 0206, 0294, 0361, 0516
SKY	0037
Skysonic	0696
SLX	0668
Smaragd	0487
Solavox	0037, 0072, 0163, 0361, 0548
Sonawa	0218
Soniko	0037
Sonitron	0208, 0370
Sonneclair	0037
Sonoko	0009, 0037, 0264, 0282
Sonolor	0163, 0208, 0282, 0361, 0548
Sontec	0009, 0037, 0294, 0370
Sony	0011, 0036, 0037, 0093, 0170, 1010, 1505, 1651
Sound & Vision-	0218, 0374
Soundesign	0178
Soundwave	0037, 0418, 0715
Spectra	0009
Ssangyong	0009
Staksonic	0009
Standard	0009, 0037, 0218, 0374, 1037
Starlite	0009, 0037, 0264
Stenway	0218, 0282
Stern	0163, 0206, 0259
Strato	0009, 0037, 0264
Sunkai	0294, 0355, 0455, 0487, 0610
Sunstar	0009, 0037, 0264, 0371, 0579
Sunwood	0037
Superla	0516
Supersonic	0009, 0208, 0455
SuperTech	0009, 0037, 0218, 0556
Supra	0009, 0178
Susumu	0218, 0335
Sutron	0009
SVA	0587
Swissline	0247
Sysline	0037
T+A	0447
Tandberg	0367
Tandy	0072, 0093, 0163, 0218

## TV (continued)

Maker	Setup codes
Tashiko	0036, 0163
Tatung	0011, 0037, 0072, 0516, 0621, 0629
TCM	0714, 0808
Teac	0009, 0037, 0170, 0178, 0264, 0282, 0412, 0418, 0455, 0512, 0668, 0698, 0706, 0712, 0714, 1037, 1909
Tec	0009, 0037, 0247, 0259, 0337
Tech Line	0037, 0668
Techica	0218
Technics	0556, 0650
TechniSat	0556, 0655
Tecnimagen	0556
Tedelex	0009, 0208, 0418, 0606
Tek	0009
Teleavia	0196
Telecor	0037, 0163, 0218, 0259
Telefunken	0037, 0073, 0074, 0084, 0109, 0196, 0335, 0346, 0486, 0560, 0587, 0625, 0698, 0712
Telefusion	0037
Telegazi	0037, 0163, 0218, 0259, 0264
Telesonic	0037
Telestar	0009, 0037, 0556, 0579
Teletech	0009, 0037, 0247, 0337, 0668, 1037
Teleton	0036, 0206, 0259
Televideon	0163
Televue	0037
Temco	0294
Tempst	0009, 0264, 0455
Tennessee	0037
Tensai	0009, 0037, 0104, 0218, 0247, 0294, 0371, 0374, 0377, 0715
Tenson	0009
Tevion	0037, 0648, 0668, 0714, 1037, 1137
Texet	0009, 0218, 0374
Thomson	0037, 0109, 0196, 0198, 0335, 0560, 0625
Thorn	0036, 0037, 0072, 0073, 0074, 0084, 0104, 0109, 0190, 0193, 0335, 0361, 0499, 0512, 0535
Thorn-Ferguson	0073, 0190, 0193, 0499
TMK	0178
Tobishi	0218
Tokai	0009, 0037, 0072, 0163, 0337, 0374, 0668, 1037
Tokaido	1037
Tomashi	0218, 0282
Tongtel	0780
Toshiba	0009, 0036, 0070, 0109, 0195, 0508, 0618, 0650, 0714, 0718, 1508
Toyoda	0009, 0264, 0371
Trakton	0009, 0264
Trans Continens	0037, 0668, 1037
TRANS-continents	0621
Transonic	0009, 0037, 0264, 0418, 0455, 0512, 0587, 0698, 0712

## Setup code chart

## TV (continued)

Maker	Setup codes
Triad	0556
Trident	0516
Tristar	0193, 0218, 0264
Triumph	0346, 0516, 0556
Tsoschi	0282
TVTEXT 95	0556
Uher	0037, 0206, 0374, 0418, 0480, 0486
Ultravox	0037, 0087, 0247
Unic Line	0037, 0455
United	0037, 0714, 0715
Universal	0037
Universum	0009, 0011, 0036, 0037, 0070, 0074, 0084, 0104, 0170, 0200, 0247, 0264, 0294, 0327, 0328, 0346, 0361, 0370, 0418, 0473, 0480, 0512, 0535, 0618, 0631, 0668, 1037
Univox	0037, 0087, 0163, 0337
Vestel	0037, 0556, 0668, 1037
Vexa	0009, 0037
Videologic	0218
Videologique	0218
Videomac	0009
Videosat	0247
VideoSystem	0037
Vidtech	0178
Vision	0037, 0264
Vistar	0206
Vortec	0037
Voxson	0087, 0163, 0178, 0418
Waltham	0037, 0109, 0163, 0418, 0668, 1037
Wards	0178
Watson	0009, 0037, 0163, 0218, 0519, 0579, 0668, 1037
Wega	0036, 0037, 0087
Wharfedale	0037, 0519, 0556
White Westinghouse	0037, 0337
Windsor	0668, 1037
Windstar	0282, 0337
Windy Sam	0556
Wintel	0714
Worldview	0455
Xenius	0634, 0661
XLogic	0698
XMS	0698
Xrypton	0037
Yamaha	0650
Yamishi	0037, 0218, 0282, 0455
Yokan	0037
Yoko	0009, 0037, 0218, 0247, 0264
Yorx	0218
Zanussi	0206, 0264

## HDTV

Maker	Setup codes
Hitachi	0719

## TV/VCR Combination

Maker	Setup codes
Aiwa	1916
Daewoo	1909
Emerson	1909
Goodmans	1909
Teac	1909

## TV/DVD Combination

Maker	Setup codes
Bush	0698, 1037

## Satellite Receiver

Maker	Setup codes
@sat	1300
@Sky	1334
ABsat	0123, 0832
ADB	0642, 1259
Aegir	0520
AGS	0710
Akai	0200
Alba	0455
Aldes	0520
Allsat	0200, 1017, 1043
Allvision	1334, 1412
Ampere	0132
Amstrad	0132, 0243, 0345, 0795, 0847, 0863, 0882, 1113, 1175
AntSat	1017, 1083
Apollo	0455
Arcon	1043, 1075, 1205
Arion	1205
Armstrong	0243
Arnion	1300
Asat	0200
ASCI	1334
AssCom	0853
AST	0321
Astacom	0710
Aston	0142, 1261
Astra	0243, 0607
Astro	0133, 0173, 0520, 0607, 0658, 1099, 1100, 1113
Atsat	1300
AtSky	1334
Aurora	0642, 0879
Austar	0497, 0642, 0863, 0879, 1259
Axiel	0710
Axis	0880, 1111
Beko	0455
Bentley Walker	1017
Bestar	0243
Black Diamond	1284
Blaupunkt	0173
Boca	0132, 0243, 0794
Boston	0710
Brand Unknown	0132, 0299, 1334
British Sky Broadcasting	0847, 1175
BskyB	0847, 1175
BT	0710, 1296
Bush	1284
Canal Digital	0853
Canal Satellite	0853
Canal+	0853
CanalSatellite	0853
Cherokee	0123, 0710
Chess	1085, 1334
CityCom	0299, 0607, 1075, 1176
Claasen Nachrichten	0520
CNT	0520
Colombia	0132
Columbia	0132
Comag	0132, 1412
Condor	0607

## Setup code chart

## Satellite Receiver (continued)

Maker	Setup codes
Conrad	0132, 0607
Conrad Electronic	0607
Crown	0243
Cryptovision	0455, 0795
Cyrus	0200
D-box	0723, 0873
Daewoo	1111, 1296
Daumling	0794
Delfa	0863
Deltasat	1075
Dgtec	1242
Digatron	1294
Digena	1100
Digenius	0299
Digitality	0607
DigiQuest	0863
DigitAll World	1227
Discovery	0710
Diseqc	0710
Distratel	1205
DMT	1075
DNT	0200
Dream Multimedia	1237
DREAM multimedia.TV	1237
DStv	0642, 0879
Echostar	0167, 0610, 0853, 0871, 1086, 1200, 1323, 1467
Einhell	0132, 0243, 0794
Elekta	0520
Elta	0200
Emme Esse	0871
Engel	1017
EP Sat	0455
Eurieult	0882
Eurocrypt	0455
Europa	0607, 0863
European	0794
Europhon	0132, 0299, 0607
Eurosat	0243
Eurosky	0132, 0243, 0299, 0607
Eurostar	0607, 0880
Ferguson	0455, 0711, 1291
Finlandia	0455
Finlux	0455
Force	1101
Force NO AS	1101
Fortec Star	1017, 1083
Foxtel	0455, 0497, 0720, 0879, 1176, 1356
Fracarro	0871
Freesat	0882
FTEmaximal	0863
Fuba	0173, 0299
Galaxis	0853, 0863, 1101, 1111
Galaxisat	0321
Garnet	1075
Gecco	1412
GF	1043
GF Star	1043
GOD Digital	0200
Gold Box	0853
Goldbox	0292, 0853

## Satellite Receiver (continued)

Maker	Setup codes
Goldvision	1017
Goodmans	0455, 1284
Gradiente	0887
Granada	0455
Grundig	0173, 0345, 0805, 0847, 0853, 0879, 1291, 1330, 1435
Hanseatic	1099, 1100
Hanuri	0520
Hauppauge	1294
HDT	1011
Helium	0607
Hirschmann	0173, 0299, 0607, 0710, 0882, 1085, 1111
Hitachi	0455
HNE	0132
Hornet	1300
HSnsel & Gretel	0132
Humax	0863, 1176, 1225
Huth	0132, 0243, 0607, 0794, 1017, 1075
Hyundai	1011, 1075
ID Digital	1176
Imex	0520
Ingelen	0882
International	0132, 0243
Interstar	1017
Intertronic	0243
Intervision	0607
InVideo	0871
IR	0173, 0282, 0455
Irdeto Technology	0879
Italtel	0871
ITT Nokia	0455, 0723, 0873
Jaeger	1334
JOK	0710
Kamm	0880
Kaon	1300
KaTelco	1111
Kathrein	0123, 0173, 0200, 0249, 0658, 1221
Kenwood	0853
Key West	0132, 0243, 0794
KeyWest	0794
Klap	0710
Konig	0607
Koscom	1043
Kreiling	0249, 0658
Kreiselmeyer	0173
L&S Electronic	0132, 1043, 1334
Labgear	1296
LaSAT	0132, 0243, 0299, 0520, 0607
Lenco	0607
LG	1075
Lifesat	0132, 0299, 1043
Lodos	1284
Loewe	0243
Logix	1017, 1075
Lorenzen	0132, 0299, 0607, 0794, 0867, 1294
Luxor	0345
Manata	0132, 0710

## Satellite Receiver (continued)

Maker	Setup codes
Manhattan	0455, 0520, 1017, 1083
Marantz	0200
Mascom	0520
Maspro	0173
Matsui	0173, 0710, 1284
Max	0607
Maximum	1075
MDS	1225
Mediacom	1206
Mediamarkt	0243
MediaSat	0292, 0853
Medion	0132, 0299, 1043, 1075, 1334, 1412
Mega	0200
Metronic	0243, 0520, 1205, 1215, 1334
Metz	0173
Micro	0607, 1294
Micromaxx	0299
Microstar	1075
Mitsubishi	0455
Morgan's	0132, 0200, 0243, 0794
Motorola	0856
Multichoice	0642, 0879
Muratto	0321
Myryad	0200
NEOTION	1334
Netgem	1322
Netsat	0887
Neuhaus	0607
Neuling	0132
Nikko	0200, 0243
Nokia	0455, 0723, 0751, 0853, 0873, 1023, 1223, 1310, 1311, 1312, 1723
Nordmende	0455, 0520
OctalTV	1294
Okano	0243
OnDigital	0133, 0241, 0751
Opentel	1412
Optex	1043
Optus	0879
Orbitech	1099, 1100
Origo	0497
OSAT	0345
Ouralis	1205
Pace	0200, 0241, 0329, 0455, 0497, 0720, 0795, 0847, 0853, 0867, 0887, 1175, 1323, 1356
Packard Bell	1111
Packsat	0710
Palcom	0299
Palladium	0243
Panasat	0615, 0879
Panasonic	0455, 0847, 1304
Panda	0173, 0455, 0607
Pansat	1011
Patriot	0132, 0710
Philips	0133, 0173, 0200, 0292, 0455, 0710, 0805, 0853, 1114
Phonotrend	0863, 1017, 1200

## Setup code chart

## Satellite Receiver (continued)

Maker	Setup codes
Pino	1334
Pioneer	0292, 0329, 0352, 0853, 1308
Planet	0871
Preisner	0132, 0794, 1101, 1113
Premier	0292
Premiere	0292, 0853, 0873
Prima	0795
Primacom	1111
Pro Visat	0520
Profile	0710
Promax	0455
ProVision	0520
Quadral	0710
Quelle	0299, 0607
Radiola	0200
Radix	0882, 1113
RFT	0200
Roadstar	0853
Saba	0520, 0607, 0710
Sabre	0455
Sagem	0820, 1114, 1253
Samsung	0853, 0863, 1017, 1206, 1243, 1292, 1293
SAT	0321
Sat Control	1300
Sat Partner	0520
Satcom	0607
SatPartner	0520
Satplus	1100
Satstation	1083
Schneider	0710, 0805, 1206
Schwaiger	0132, 0607, 0863, 1075, 1083, 1111, 1334
SCS	0299
Sedea Electronique	0132, 1206
Seemann	0243
SEG	1075, 1087
Seleco	0871
Septimo	1205
Serino	0610
Siemens	0173
Silva	0299
SKY	0711, 0847, 0856, 0887, 1014, 1175
Sky Television	1014
SKY+	1175
Skymaster	0880, 1075, 1085, 1200
Skymax	0200
Skyplus	1334, 1412
SkySat	0607
Skyvision	1334
SL	0132, 0243, 0299, 1294
SM Electronic	1200
Smart	0132, 0299, 0794, 0882, 1101, 1113
Sony	0282, 0292, 0847, 0853
SR	0132
Starlite	0200
Strong	0132, 0520, 0853, 0879, 1300
Sunkai	0123
Sunstar	0132, 0243, 0642, 0794

## Satellite Receiver (continued)

Maker	Setup codes
Supernova	0887
Tantec	0455
Tarbs	1225
Tatung	0455
Teac	1225, 1227, 1322
Tecatel	1200
TechniSat	0200, 0455, 0863, 1099, 1100, 1195, 1322
Technowelt	0132, 0607
Techsan	1017
Techwood	1284
Teco	0243
tekComm	1017
Telasat	0607
Teleciel	1043
Telefunken	0710
Teleka	0243, 0607
Telemaster	0520
Telestar	1099, 1100, 1334
Teletech	0880
Televes	0132, 0455, 1300
Televisa	0887
Thomson	0292, 0455, 0607, 0710, 0711, 0820, 0847, 0853, 1046, 1291
Thorn	0455
Tioko	0132, 0243
Tokai	0200
Tonna	0455
Topfield	1206
Toshiba	0455
TPS	0820, 1253
Triad	0321
Triax	0132, 0200, 0853, 1099, 1113, 1227, 1291, 1296
Trio	1075
UEC	0879
Unisat	0132, 0200, 0243
Universum	0173, 0299, 0607, 1087, 1099
Variosat	0173
Ventana	0200
VH-Sat	0299
Visiosat	0142, 0710
Viva	0856
VTech	0321
Wewa	0455
Wibo	0243
Wintel	0299
Wisi	0173, 0299, 0321, 0455, 0607
Woorisat	0520
Worldsat	0123, 0710, 1323
XCOM	0123, 0832
Xsat	0123, 0847, 1323
Xtreme	1300
Yes	0887
Zehnder	0321, 0520, 1075, 1334, 1412
Zenith	0856
Zwergnase	0243, 0794

## Cable Converter

Maker	Setup codes
ABC	0003
ADB	1063, 1269
Alcatel	0896
Amstrad	1222
Austar	0276
Birmingham Cable Communications	0276
British Telecom	0003
Cable & Wireless	1068
Cabletime	0448, 0665
Comcrypt	0443
Comtec	0019
Contec	0019
Cryptovision	0600
Filmnet	0443
Foxtel	1222
France Telecom	0451, 0817, 0896
Galaxi	0008
General Instruments	0003, 0276
Golden Channel	1063, 1110
HyperVision	0619
i-CAN	1063
Jerrold	0003, 0276
Kabelvision	0003
Macab	0817
Melita	0003
MNET	0019, 0443
Motorola	0276, 1106
Mr Zap	1112
Mr Zapp	0817
Mr. Zap	1112
Multichoice	0019, 0443
Noos	0817
NTL	0003, 0250, 0276, 0277, 1060, 1068
Oak	0019
Ono	1068
Optus	0276, 1060
Pace	1060, 1068
Panasonic	0000
Paragon	0000
Philips	0619, 0817
Pioneer	0144
Pulsar	0000
PVP Stereo Visual Matrix	0003
Runco	0000
Sagem	0817, 1112
Salora	0000
Samsung	1060
Scientific Atlanta	0008, 0277, 1068
Starcom	0003
Supercable	0276
Tele Danmark	0619
Tele+1	0443
Teledanmark	0619
Telepiu	0443
Telewest	1068
Thomson	1110
Torx	0003
TransACT	1106
United Cable	0003
US Electronics	0276

## Setup code chart

## Cable Converter (continued)

Maker	Setup codes
Videotron	0250
Videoway	0250
Visionetics	1064
Visiopass	0451, 0817
Zenith	0000

## VCR

Maker	Setup codes
Accent	0072
Adyson	0072
Aim	0020, 0278
Aiwa	0000, 0037, 0307, 0348, 0352, 0687, 0734, 0742, 1137
Akai	0020, 0037, 0041, 0106, 0240, 0315, 0348, 0352, 0642
Akiba	0072
Akura	0072
Alba	0000, 0020, 0072, 0081, 0278, 0315, 0348, 0352
Allorgan	0240
Allstar	0081
Ambassador	0020
America Action	0278
Amstrad	0000, 0072, 0278, 1942
Anam	0037, 0226, 0240
Anam National	0226
Anitech	0072
Ansonic	0000
Aristona	0081
ASA	0037, 0081
Asuka	0037, 0038
AudioSonic	0278
Audioton	0020
AVA Technology	0615
AVP	0000, 0352
Awa	0037, 0043, 0278, 0642
Baird	0000, 0041, 0104, 0106
Bang & Olufsen	0499
Basic Line	0020, 0072, 0104, 0278
Beko	0104
Bell & Howell	0104
Bestar	0020, 0278
Black Diamond	0642
Black Panther	0278
Blaupunkt	0081, 0195, 0226
Blue Sky	0037, 0072, 0278, 0348, 0352, 0480, 0642, 1137
Bondstec	0020, 0072
Brand Unknown	0104, 0348
Brandt	0041, 0320, 0321, 0493
Brandt Electronic	0041
Brandt Electronique	0041
Brinkmann	0348
British Sky Broadcasting	1942
Bush	0000, 0072, 0081, 0278, 0315, 0348, 0352, 0642
Carena	0081
Carrefour	0045
Carver	0081
Casio	0000
Cathay	0278
Catron	0020
CGE	0000, 0041
Cimline	0072
Citizen	0037, 0278
Clatronic	0000, 0020, 0072
Colt	0072
Combitech	0352
Condor	0020, 0278

## VCR (Continued)

Maker	Setup codes
Craig	0037, 0072, 0240
Crown	0020, 0037, 0072, 0278, 0480
Cyrus	0081
Daewoo	0020, 0045, 0278, 0352, 0637, 0642
Dansai	0072, 0278
Dantax	0352
Daytron	0020, 0278
De Graaf	0042, 0048, 0081, 0104, 0166
Decca	0000, 0041, 0067, 0081, 0352
Deitron	0278
Denko	0072
Denon	0042
Diamant	0037
Diamond	0348
Dream Multimedia	1968
DREAM multimedia.TV	1968
Dual	0000, 0041, 0081, 0278, 0348
Dumont	0000, 0081, 0104
Elbe	0038, 0278
Elcatech	0072
Elin	0240
Elsay	0072
Elta	0072, 0278
Emerson	0000, 0037, 0043, 0045, 0072, 0278, 0593, 0637
ESC	0020, 0240, 0278
Etzuko	0072
Europhon	0020
Fenner	0020
Ferguson	0000, 0041, 0278, 0320, 0321, 0493
Fidelity	0000, 0072, 0240, 0352, 0432
Finlandia	0000, 0037, 0042, 0043, 0048, 0081, 0104, 0106, 0166, 0226, 0384
Finlux	0000, 0042, 0081, 0104
Firstline	0037, 0043, 0045, 0072, 0278, 0348, 0480, 1137
Fisher	0020, 0104
Flint	0348
Frontech	0020, 0072
Fujitsu	0000
Fujitsu General	0037
Funai	0000
Galaxi	0000
Galaxis	0278
Garrard	0000
GBC	0020
GE	0048, 0240, 0320
GEC	0081
General	0020
General Technic	0348
Genexxa	0104
Go Video	0432, 0620
GoldHand	0072
GoldStar	0037, 0480
Goodmans	0000, 0020, 0037, 0072, 0081, 0278, 0348, 0352, 0637, 0642

## Setup code chart

## VCR (Continued)

Maker	Setup codes
GPX	0037
Gradiente	0000
Graetz	0041, 0104, 0240
Granada	0000, 0037, 0042, 0048, 0081, 0104, 0226, 0240
Grandin	0000, 0020, 0037, 0072, 0278
Grundig	0072, 0081, 0195, 0226, 0320, 0347, 0348, 0352, 0742
Haaz	0348
Hanimex	0352
Hanseatic	0037, 0038, 0081
Hantor	0020
Harley Davidson	0000
Harman/Kardon	0038
Harwood	0072
HCM	0072
Hinari	0041, 0072, 0240, 0278, 0352
Hisawa	0352
Hischito	0045
Hitachi	0000, 0041, 0042, 0081, 0166, 0240, 0593
Hornophon	0081
Hughes Network Syst	0042
Hypson	0000, 0037, 0072, 0278, 0352, 0480
H_er	0278, 0642
Impego	0020
Imperial	0000
Ingersoll	0240
Inno Hit	0020, 0072
Interbuy	0037, 0072
Interfunk	0081, 0104
Internal	0278, 0637
International	0037, 0278, 0642
Intervision	0000, 0278
IR	0020, 0041, 0042, 0045, 0072, 0081, 0104, 0106, 0226, 0240, 0348
Irradio	0037, 0072, 0081
ITT	0041, 0104, 0106, 0240, 0384
ITV	0020, 0037, 0278
ITV Videomaster	0020
JBL	0278
Jensen	0041
JMB	0348, 0352, 0742
Joyce	0000
JVC	0041, 0067, 0081, 0384
Kaisui	0072
Kambrook	0037
Karcher	0081, 0278
KEC	0037, 0278
Kendo	0072, 0106, 0278, 0315, 0348, 0642
Kenwood	0038, 0041, 0067
KIC	0000
Kneissel	0037, 0278, 0348, 0352
Korpel	0072
Kuwa	0226
Kyoto	0072
Lenco	0278

## VCR (Continued)

Maker	Setup codes
Leyco	0072
LG	0037, 0480, 1137
Lifetec	0348
Lloyd's	0000
Loewe	0037, 0081, 1562
Logik	0072, 0106, 0240
Lumatron	0593
Lux May	0072
Luxor	0043, 0048, 0104, 0106, 0315
LXI	0037
M Electronic	0000, 0038
Magnasonic	0278, 0593
Magnavox	0000, 0081, 0642
Magnin	0240
Magnum	0642
Manesth	0045, 0072, 0081
Marantz	0038, 0081
Mark	0000, 0020, 0278
Master's	0278
Matsui	0240, 0278, 0348, 0352, 0687, 0742
Mediator	0081
Medion	0348, 0352, 0642
Melectronic	0000, 0037, 0038
Memorex	0000, 0037, 0048, 0104, 0240, 0348
Memphis	0072
Mercury	0020
Metronic	0081
Metz	0037, 0081, 0195, 0226, 0347, 0836, 1562
MGA	0043, 0240
Micormay	0348
Migros	0000
Minerva	0195
Minolta	0042
Mitsubishi	0000, 0043, 0048, 0067, 0081, 0480, 0642
MTC	0000, 0240
Multitec	0037
Multitech	0000, 0020, 0072
Murphy	0000
Myryad	0081
NAD	0104
Naiko	0642
National	0226
NEC	0037, 0038, 0041, 0067, 0104, 0278
Neckermann	0081
Nesco	0000, 0072
Nikkai	0020, 0072, 0278
Nikko	0037
Nokia	0041, 0042, 0048, 0081, 0104, 0106, 0240, 0278, 0315
Nordmende	0041, 0067, 0320, 0321, 0384, 0493
Oceanic	0000, 0041, 0048, 0081, 0104, 0106
Okano	0072, 0278, 0315, 0348
Onimax	0642
Optimus	0037, 0048, 0104, 0432, 0593

## VCR (Continued)

Maker	Setup codes
Orbit	0072
Orion	0348, 0352, 0687, 0742
Orson	0000
Osaki	0000, 0037, 0072
Osume	0072
Otto Versand	0081
Pace	0352, 1942
Pacific	0000, 0348, 0642
Palladium	0037, 0041, 0072, 0348
Palsonic	0000, 0072, 0642
Panasonic	0226, 0836, 1562, 1662
Pathe Cinema	0043
Pathe Marconi	0041
Penney	0037, 0038, 0042, 0240
Pentax	0042
Perdio	0000
Philco	0038, 0072
Philips	0081, 0384, 0593
Phoenix	0278
Phonola	0081
Pilot	0037
Pioneer	0042, 0067, 0081
Portland	0020, 0278, 0637
Prinz	0000
Profitronic	0081, 0240
Proline	0000, 0278, 0320, 0321, 0615, 0642
Prosco	0278
Prosonic	0278
Protech	0081
ProVision	0278
Pye	0000, 0081
Quasar	0278
Quelle	0081
Radialva	0037, 0048, 0072, 0081
Radiola	0081
Radionette	0037, 1137
RadioShack	0000, 0037
Rank	0041
Rank Arena	0041
RCA	0042, 0048, 0240, 0320
Realistic	0000, 0037, 0048, 0104
Reoc	0348
Rex	0041, 0384
RFT	0020, 0072
Roadstar	0037, 0072, 0081, 0240, 0278, 0742
Royal	0072
Saba	0041, 0278, 0320, 0321, 0384
Saisho	0348
Salora	0043, 0104, 0106
Samsung	0045, 0240, 0432, 0620
Samurai	0020
Sansei	0048
Sansui	0000, 0041, 0067, 0072, 0106, 0348
Sanyo	0048, 0067, 0104, 0240, 0348
Saville	0240, 0278, 0352
SBR	0081
Schaub Lorenz	0000, 0041, 0104, 0106, 0315, 0348

## Setup code chart

### VCR (Continued)

Maker	Setup codes
Schneider	0000, 0037, 0042, 0072, 0081, 0240, 0278, 0348, 0352, 0642
Scott	0043
Sears	0000, 0037, 0042, 0104
Seaway	0278
SEG	0072, 0081, 0240, 0278, 0637, 0642
SEI	0081
Sei-Sinudyne	0081
Seleco	0020, 0037, 0041, 0384
Semp	0045
Senra	0020, 0072
Setron	0072
Sharp	0037, 0048, 0569
Shintom	0072, 0104
Shivaki	0037
Siemens	0037, 0081, 0104, 0195, 0320, 0347
Siera	0081
Silva	0037
Silver	0278
Singer	0045, 0348
Sinudyne	0081, 0352
Smaragd	0348
Solavox	0020
Sonneclair	0072
Sontec	0037
Sony	0000, 0032, 0106, 1032
Soundwave	0037, 0348
Ssangyong	0072
Standard	0278
Stern	0278
Sunkai	0278, 0348
Sunstar	0000
Suntronic	0000
Sunwood	0072
Supra	0037, 0278, 0348
Sylvania	0043, 0081
Symphonic	0000, 0593
Tandberg	0278
Tandy	0000, 0104
Tashiko	0000, 0037, 0048, 0081, 0240
Tatung	0000, 0041, 0043, 0048, 0081, 0348, 0352
Tchibo	0348
TCM	0348
Teac	0000, 0037, 0041, 0072, 0278, 0307, 0593, 0637, 0642
Tec	0020, 0072
Tech Line	0072
Technics	0081, 0226
TechniSat	0348
Tedelex	0037, 0348
Teknika	0000, 0037
Teleavia	0041, 0493
Telefunken	0041, 0278, 0320, 0321, 0384, 0493, 0642
Telestar	0037
Teletech	0000, 0072, 0278
Tempest	0020
Tenosal	0072

### VCR (Continued)

Maker	Setup codes
Tensai	0000, 0072, 0278
Tevion	0348, 0642
Texet	0020, 0278
Thomas	0000
Thomson	0041, 0067, 0278, 0320, 0321, 0384, 0493, 0722
Thorn	0037, 0041, 0104
Tivo	0722
Tokai	0037, 0041, 0072, 0104
Topline	0348
Toshiba	0041, 0043, 0045, 0081, 0352, 0384, 0432, 0742
Totevision	0037
Towada	0072
Tradex	0081
Trakton	0020
Triad	0278
TVA	0020
Uher	0240
Ultravox	0278
Unitech	0240
United	0348
United Quick Star	0278
Universum	0000, 0037, 0081, 0104, 0106, 0195, 0240, 0348, 1137
Victor	0067
Video Concepts	0045
Video Pro	0020
Video Technic	0000
Videomagic	0037
VideoPro	0020
Videosonic	0240
Villain	0000
Wards	0000, 0038, 0042, 0045, 0048, 0072, 0081, 0240
Watson	0081, 0352, 0642
Weltblick	0037
Wewa	0493
Wharfedale	0593, 0615, 0642
White Westinghouse	0072, 0278
World	0348
Yamaha	0038
Yamishi	0072, 0278
Yokan	0072
Yoko	0020, 0037, 0072, 0240
Zenith	0000, 0637
ZX	0348, 0352

### Video Accessories

Maker	Setup codes
Macro Image Technology	1383
Motorola	1363
MyHD	1383
Panasonic	1120
Pioneer	1010
Sharp	1010
Samsung	1490
Sensory Science	1126
Viewsonic	1329

### PVR

Maker	Setup codes
Dream Multimedia	1968
Pace	1942
SKY	1942
Thomson	0722
Tivo	0722

### CD player

Maker	Setup codes
Genexxa	0037
Kenwood	0028, 0037, 0190, 0339, 0523, 0677, 0681, 0826, 0858, 0859, 1338, 1339, 0340, 1490
Optimus	0037
Sharp	0037
Trio	0677

### MD recorder

Maker	Setup codes
Kenwood	1339, 0681, 0826

## Other components' operations

Refer to the following for the type of remote control operations available for each component.

- 1 Select the input source.
- 2 Press the keys corresponding to the operations you desire. Refer to the following sections for details.

- When pressing keys in succession, press each key firmly and be sure to wait at least 1 second before pressing the next key.
- Numeric keys function the same as the numeric keys on the original remote.
- The key descriptions in this section are for representative components.

These keys can be used to perform the basic operations of KENWOOD and other manufacturers' components which the setup code for each component had been entered beforehand.

### DVD player operations keys

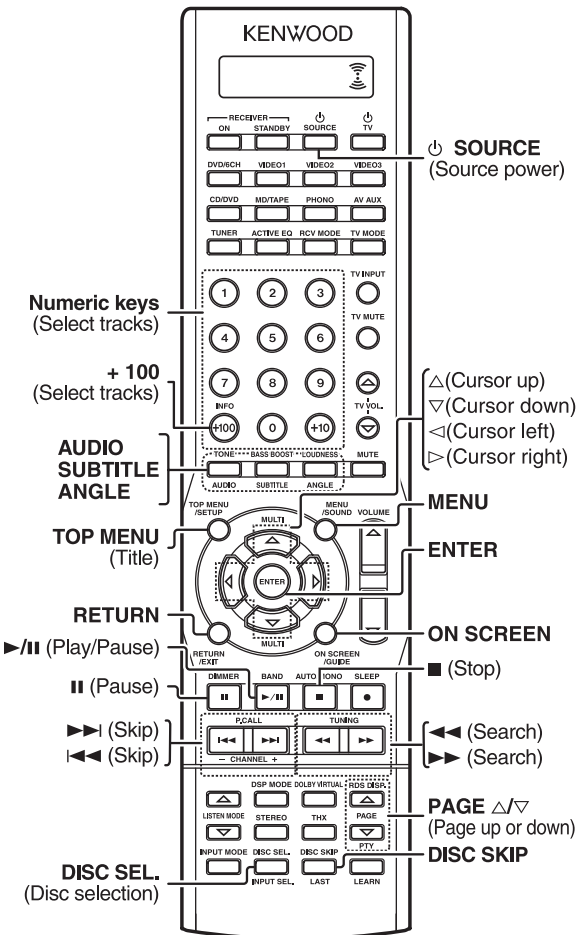

### TV operation keys (including TVs incorporating VCR)

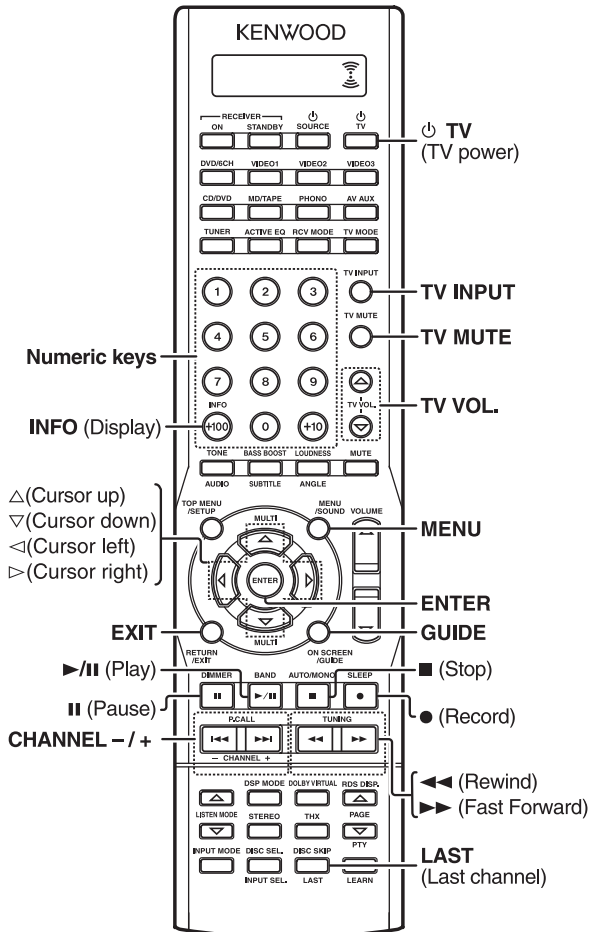

## Basic remote control operations for other components

Refer to the following for the type of remote control operations available for each component.

### Satellite Receiver operation keys

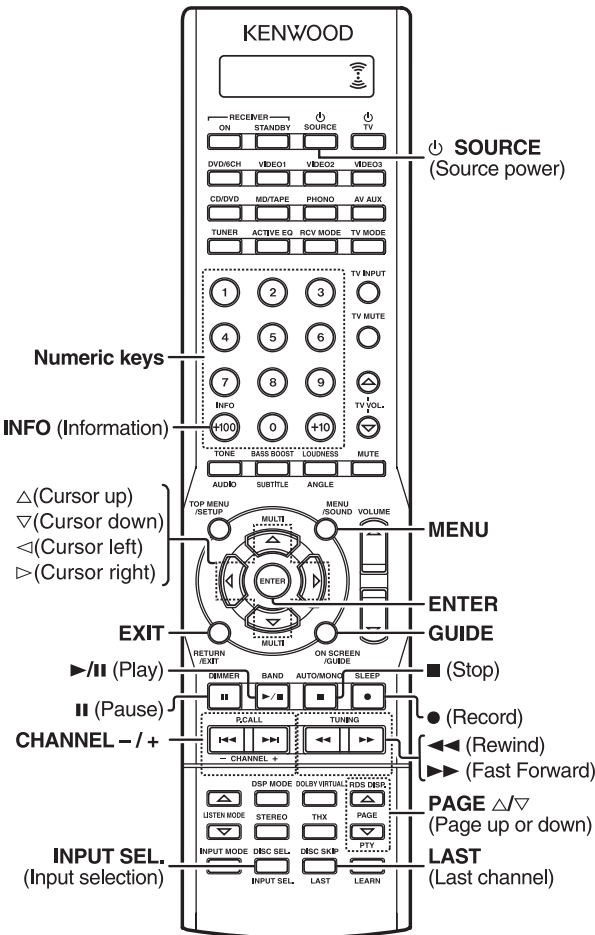

### Cable converter operation keys

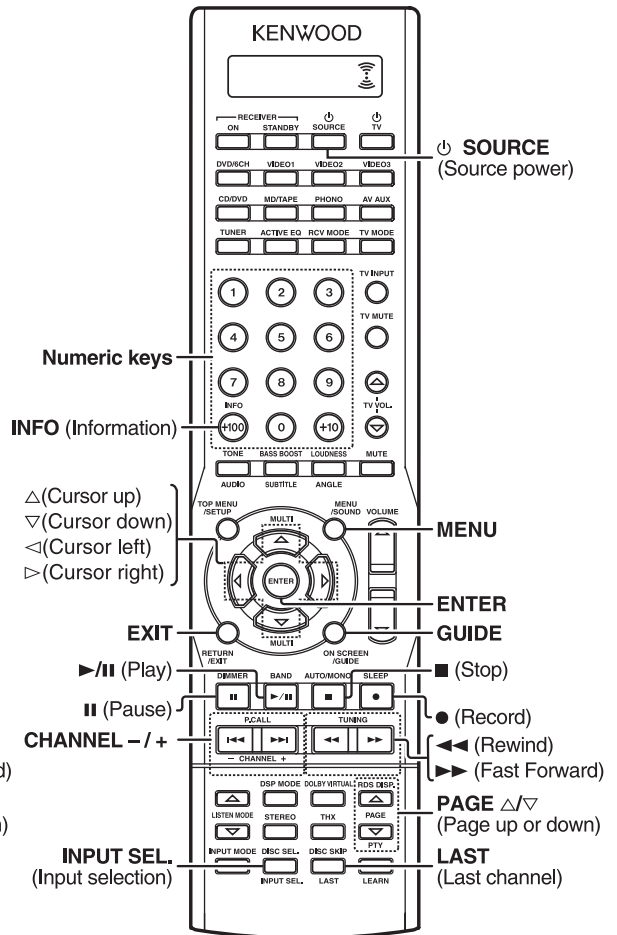

## Basic remote control operations for other components

Refer to the following for the type of remote control operations available for each component.

### VCR operation keys

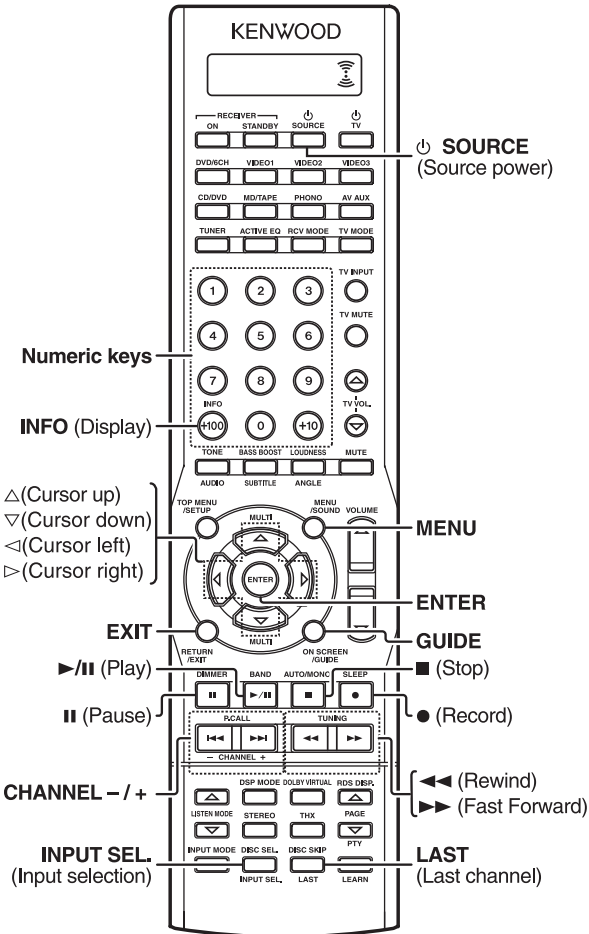

### CD player operation keys

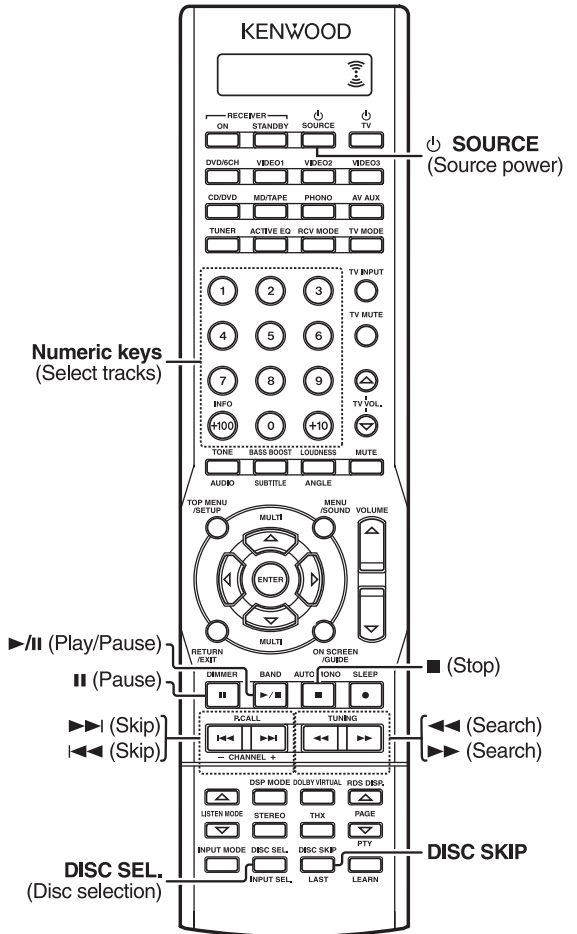

## Basic remote control operations for other components

Refer to the following for the type of remote control operations available for each component.

### MD recorder operation keys (made by KENWOOD)

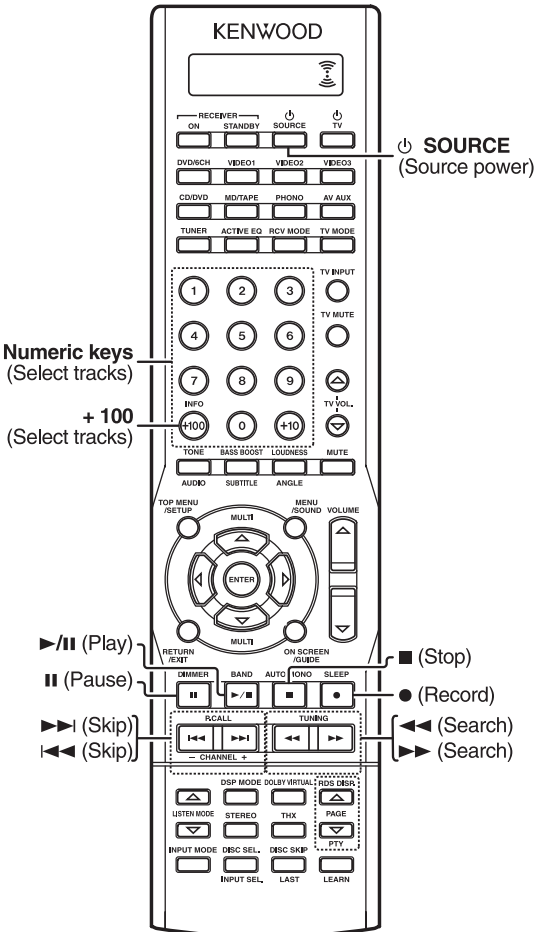

#### Notes

1. Certain codes may only operate some of the function available on a given model.
2. The above show the typical type functions available for each component. Some manufacturers use different key combinations to perform similar functions. For that reason, we have programmed extra functions on some of the unused number keys to help you control your equipment.

## In case of difficulty

### Resetting the Microcomputer

The microcomputer may malfunction (unit cannot be operated, or shows an erroneous display) if the power cord is unplugged while the power is ON, or due to some other external factor. If this happens, execute the following procedure to reset the microcomputer and return the unit to its normal operating condition.

**With the power cord plugged in, turn the POWER ON/OFF key OFF. Then, while holding down the  (ON/STANDBY) key, press POWER ON/OFF key.**

- Please note that resetting the microcomputer will clear the contents of the memory and returns the unit to the state it was in when it left the factory.

### Amplifier

Symptom	Cause	Remedy
<b>No sound from the speakers.</b>	<ul style="list-style-type: none"> <li>• The speaker cords are disconnected.</li> <li>• VOLUME is set to the minimum position.</li> <li>• MUTE is ON.</li> <li>• The SPEAKERS switches are set to OFF.</li> <li>• Headphones are connected to the PHONES jack.</li> </ul>	<ul style="list-style-type: none"> <li>• Connect them properly referring to "Connecting the speakers" <a href="#">- [15]</a></li> <li>• Adjust the volume to a proper level. <a href="#">- [26]</a></li> <li>• Turn OFF the MUTE. <a href="#">- [28]</a></li> <li>• Set the SPEAKERS switches to ON. <a href="#">- [26]</a></li> <li>• Unplug the headphones plug. <a href="#">- [28]</a></li> </ul>
<b>The STANDBY indicator blinks and sound is not output.</b>	<ul style="list-style-type: none"> <li>• Speaker cords are short-circuited.</li> </ul>	<ul style="list-style-type: none"> <li>• Turn the power off, eliminate the short-circuiting, then turn on the power again.</li> </ul>
<b>Sound is not output from one of the speakers.</b>	<ul style="list-style-type: none"> <li>• The speaker cord is disconnected.</li> <li>• The speaker is not set up correctly.</li> </ul>	<ul style="list-style-type: none"> <li>• Connect it properly referring to "Connecting the speakers" <a href="#">- [15]</a></li> <li>• Set it up properly referring to "Preparing for surround sound" <a href="#">- [19]</a></li> </ul>
<b>Sound is not output from the surround speakers and / or the center speaker, or their sound is very small.</b>	<ul style="list-style-type: none"> <li>• The surround speaker cords and/or the center speaker cord is disconnected.</li> <li>• The speaker is not set up correctly.</li> <li>• A surround mode has not been engaged.</li> <li>• The surround and/or center volume controls are set to the minimum level.</li> </ul>	<ul style="list-style-type: none"> <li>• Connect it properly referring to "Connecting the speakers" <a href="#">- [15]</a></li> <li>• Set it up properly referring to "Preparing for surround sound" <a href="#">- [19]</a></li> <li>• Select a surround mode.</li> <li>• Adjust the speaker levels using the test tone. <a href="#">- [23]</a></li> </ul>
<b>A humming noise is generated when the PHONO input selector is selected.</b>	<ul style="list-style-type: none"> <li>• The audio cord from the record player is not connected to the PHONO jacks.</li> <li>• The record player is not grounded.</li> </ul>	<ul style="list-style-type: none"> <li>• Insert the audio cord plugs securely into the PHONO jacks.</li> <li>• Connect the grounding wire to the GND terminal on the rear panel.</li> </ul>
<b>When playing a Dolby Digital source signal using a DVD player, the sound is cut off soon after it starts.</b>	<ul style="list-style-type: none"> <li>• There are many possible causes for this problem, depending on the type of DVD player used.</li> </ul>	<ul style="list-style-type: none"> <li>• Set the input mode to digital manual before starting playback of the Dolby Digital source. <a href="#">- [8]</a></li> </ul>
<b>No sound is produced during playback from a DVD player.</b>	<ul style="list-style-type: none"> <li>• The input mode is set to digital manual.</li> </ul>	<ul style="list-style-type: none"> <li>• Press the <b>INPUT MODE</b> key to select to full auto mode. <a href="#">- [8]</a></li> </ul>
<b>A video source cannot be recorded normally.</b>	<ul style="list-style-type: none"> <li>• The software is copy-guarded.</li> </ul>	<ul style="list-style-type: none"> <li>• Copy-guarded video software cannot be recorded.</li> </ul>
<b>Display such as Exx : XXX appears.</b>	<ul style="list-style-type: none"> <li>• Problems are detected while in AUTO SETUP calibration.</li> </ul>	<ul style="list-style-type: none"> <li>• Refer to "About error messages" and "About warning messages" <a href="#">- [21]</a></li> </ul>

**Tuner**

Symptom	Cause	Remedy
Radio stations cannot be received.	<ul style="list-style-type: none"> <li>No antenna is connected.</li> <li>The broadcast band is not set properly.</li> <li>The frequency of the desired station is not tuned.</li> </ul>	<ul style="list-style-type: none"> <li>Connect an antenna. → 18</li> <li>Set the broadcast band properly.</li> <li>Tune the frequency of the desired station. → 30</li> </ul>
Interference.	<ul style="list-style-type: none"> <li>Noise due to ignition noise from an automobile.</li> <li>Noise due to interference from an electric appliance.</li> <li>Noise due to a nearby TV set.</li> </ul>	<ul style="list-style-type: none"> <li>Install the outdoor antenna away from the road.</li> <li>Turn off the power to the appliance.</li> <li>Install the receiver farther away from the TV.</li> </ul>
A station which was preset cannot be received by pressing the corresponding numeric key.	<ul style="list-style-type: none"> <li>The preset station belongs to a frequency that cannot be received.</li> <li>The preset memory was cleared because the power cord had been unplugged for a long period of time.</li> </ul>	<ul style="list-style-type: none"> <li>Preset a station with a receivable frequency.</li> <li>Preset the station again.</li> </ul>

**Remote control unit**

Symptom	Cause	Remedy
Certain inputs cannot be selected using the remote control.	<ul style="list-style-type: none"> <li>No setup codes registered for the respective input(s).</li> </ul>	<ul style="list-style-type: none"> <li>Register a setup code at the respective input(s). → 43</li> </ul>
Remote control operation is not possible.	<ul style="list-style-type: none"> <li>The remote control unit is set to a different operation mode.</li> <li>Batteries are exhausted.</li> <li>The remote control unit is too far away from the main system, controlling angle is too large, or there is an obstacle between the receiver and the remote.</li> <li>No disc or tape is placed in the source component.</li> <li>An attempt is made to play a tape which is being recorded in the cassette deck.</li> <li>The remote control has not been set to the operation mode for the component you wish to control.</li> </ul>	<ul style="list-style-type: none"> <li>Press the <b>RCV MODE</b> key to select the appropriate operation mode.</li> <li>Replace with new batteries.</li> <li>Operate the remote control unit within the controllable range.</li> <li>Place the disc or tape in the source component which you want to play.</li> <li>Wait until recording has completed.</li> <li>Press any of the <b>Source</b> keys or <b>⏻ SOURCE</b> key to activate the operation mode for the component you want to control before operation. → 43</li> </ul>

# Specifications

⚠ Caution : Read this page carefully to ensure safe operation.

## AUDIO section

For Europe

Rated power output during STEREO operation	
IEC (20 Hz ~ 20 kHz, 0.09% T.H.D., at 6 Ω) .....	100 W + 100 W
DIN (1 kHz at 6 Ω) .....	120 W + 120 W
Effective power output during STEREO operation	
RMS (1 kHz, 10% T.H.D., at 6 Ω) .....	150 W + 150 W
Effective power output during SURROUND operation	
FRONT	
(20 Hz ~ 20 kHz, 0.09% T.H.D., at 6 Ω one channel driven) .....	100 W + 100 W
(1 kHz, 0.7% T.H.D., at 6 Ω one channel driven) ..	120 W + 120 W
(1 kHz, 10% T.H.D., at 6 Ω one channel driven) ...	150 W + 150 W
CENTER	
(20 Hz ~ 20 kHz, 0.09% T.H.D., at 6 Ω one channel driven) .....	100 W
(1 kHz, 0.7% T.H.D., at 6 Ω one channel driven) .....	120 W
(1 kHz, 10% T.H.D., at 6 Ω one channel driven) .....	150 W
SURROUND	
(20 Hz ~ 20 kHz, 0.7% T.H.D., at 6 Ω one channel driven) .....	100 W + 100 W
(1 kHz, 0.7% T.H.D., at 6 Ω one channel driven) ..	120 W + 120 W
(1 kHz, 10% T.H.D., at 6 Ω one channel driven) ...	150 W + 150 W
SURROUND BACK	
(20 Hz ~ 20 kHz, 0.7% T.H.D., at 6 Ω one channel driven) .....	100 W + 100 W
(1 kHz, 0.7% T.H.D., at 6 Ω one channel driven) ..	120 W + 120 W
(1 kHz, 10% T.H.D., at 6 Ω one channel driven) ...	150 W + 150 W
Total harmonic distortion .....	0.009% (1 kHz, 50 W, 6 Ω)

For Australia

Rated power output during STEREO operation	
IEC (20 Hz ~ 20 kHz, 0.09% T.H.D., at 8 Ω) .....	100 W + 100 W
DIN (1 kHz at 8 Ω) .....	120 W + 120 W
Effective power output during STEREO operation	
(1 kHz, 10% T.H.D., at 8 Ω) .....	130 W + 130 W
Effective power output during SURROUND operation	
FRONT	
(20 Hz ~ 20 kHz, 0.09% T.H.D., at 8 Ω one channel driven) .....	100 W + 100 W
(1 kHz, 0.7% T.H.D., at 8 Ω one channel driven) ...	120 W + 120 W
(1 kHz, 10% T.H.D., at 8 Ω one channel driven) ...	130 W + 130 W
CENTER	
(20 Hz ~ 20 kHz, 0.09% T.H.D., at 8 Ω one channel driven) .....	100 W
(1 kHz, 0.7% T.H.D., at 8 Ω one channel driven) .....	120 W
(1 kHz, 10% T.H.D., at 8 Ω one channel driven) .....	130 W
SURROUND	
(20 Hz ~ 20 kHz, 0.7% T.H.D., at 8 Ω one channel driven) .....	100 W + 100 W
(1 kHz, 0.7% T.H.D., at 8 Ω one channel driven) ..	120 W + 120 W
(1 kHz, 10% T.H.D., at 8 Ω one channel driven) ...	130 W + 130 W
SURROUND BACK	
(20 Hz ~ 20 kHz, 0.7% T.H.D., at 8 Ω one channel driven) .....	100 W + 100 W
(1 kHz, 0.7% T.H.D., at 8 Ω one channel driven) ..	120 W + 120 W
(1 kHz, 10% T.H.D., at 8 Ω one channel driven) ...	130 W + 130 W
Total harmonic distortion .....	0.009% (1 kHz, 50 W, 8 Ω)

Frequency response	
CD/DVD .....	10 Hz ~ 100 kHz, +0 dB ~ -3.0 dB
PHONO 'RIAA' response .....	40 Hz ~ 20 kHz, +1.5 dB ~ -3.0 dB
Maximum input level	
PHONO (MM) .....	40 mV, 1% T.H.D., at 1 kHz
Signal to noise ratio (IHF'66)	
PHONO (MM) .....	75 dB
CD/DVD .....	95 dB
Input sensitivity / impedance	
PHONO (MM) .....	4 mV / 47 kΩ
CD/DVD, MD/TAPE, AV AUX, VIDEO 1, VIDEO 2, VIDEO 3, DVD/6CH .....	300 mV / 47 kΩ

Output level / impedance	
REC OUT (MD/TAPE) .....	300 mV / 1 kΩ
PRE OUT (FRONT) .....	1 V / 500 Ω
PRE OUT (CENTER) .....	1 V / 500 Ω
PRE OUT (SURROUND) .....	1 V / 500 Ω
PRE OUT (SURROUND BACK) .....	1 V / 500 Ω
PRE OUT (SUBWOOFER) .....	1 V / 500 Ω
Tone control	
BASS .....	±10 dB (at 100 Hz)
TREBLE .....	±10 dB (at 10 kHz)
Loudness control	
VOLUME at -30 dB level .....	+6 dB (100 Hz)

## DIGITAL AUDIO section

Sampling frequency .....	32 kHz, 44.1 kHz, 48 kHz, 96 kHz
Input level / impedance / wave length	
Optical .....	-15 dBm ~ -24 dBm, 660 nm ±30 nm
Coaxial .....	0.5 Vp-p / 75 Ω
Output level / impedance / wave length	
Optical .....	-21 dBm ~ -15 dBm, 660 nm ±30 nm

## VIDEO section

VIDEO inputs / outputs	
VIDEO (composite) .....	1 Vp-p / 75 Ω
S VIDEO inputs / outputs	
S VIDEO (luminance signal) .....	1 Vp-p / 75 Ω
S VIDEO (chrominance signal) .....	0.286 Vp-p / 75 Ω
COMPONENT VIDEO inputs / outputs	
COMPONENT VIDEO (luminance signal) .....	1 Vp-p / 75 Ω
COMPONENT VIDEO (CB/CR-signal) .....	0.7 Vp-p / 75 Ω

## FM tuner section

Tuning frequency range .....	87.5 MHz ~ 108.0 MHz
Usable sensitivity	
MONO .....	1.3 μV (75 Ω) / 13.2 dBf (40 kHz dev, S/N 26 dB)
STEREO .....	45 μV (75 Ω) / 42.1 dBf (40 + 6 kHz dev, S/N 46 dB)
Total harmonic distortion	
MONO (1 kHz, 40 kHz dev) .....	0.2% (65.2 dBf input)
STEREO (1 kHz, 40 + 6 kHz dev) .....	0.8% (65.2 dBf input)
Signal to noise ratio (DIN weighted at 1 kHz)	
MONO .....	65 dB (65.2 dBf input)
STEREO .....	60 dB (65.2 dBf input)
Stereo separation (1 kHz) .....	36 dB
Selectivity (DIN ±300 kHz) .....	64 dB
Frequency response (30 Hz ~ 15 kHz) .....	+0.5 dB, -3.0 dB

## AM tuner section

Tuning frequency range .....	531 kHz ~ 1,602 kHz
Usable sensitivity (30% mod, S/N 20 dB) .....	16 μV / (600 μV/m)
Signal to noise ratio (30% mod, 400 Hz) .....	50 dB (60 dBμV EMF input)

## GENERAL

Power consumption	
For Europe .....	330 W
Foe Australia .....	300 W
Standby Power consumption .....	Less than 2.0 W
AC outlet	
SWITCHED .....	total 90 W max.
Dimensions .....	
W : 440 mm (17-5/16")	H : 166 mm (6-9/16")
	D : 396 mm (15-9/16")
Weight (Net)	
For Europe .....	12.3 kg (27.1 lb)
For Australia .....	12.1 kg (26.6 lb)

## Notes

1. KENWOOD follows a policy of continuous advancements in development. For this reason specifications may be changed without notice.
2. The full performance may not be exhibited in an extremely cold location (under a water-freezing temperature).

# KENWOOD

## For your records

Record the serial number, found on the back of the unit, in the spaces designated on the warranty card, and in the space provided below. Refer to the model and serial numbers whenever you call upon your dealer for information or service on this product.

Model \_\_\_\_\_ Serial Number \_\_\_\_\_